

- ROBUST ALUMINIUM CONSTRUCTION
- 200N OR 500N HOLDING FORCE
- MANUAL RELEASE SWITCH
- SURFACE CABLE ENTRY
- SUPPLIED WITH KEEPER PLATE

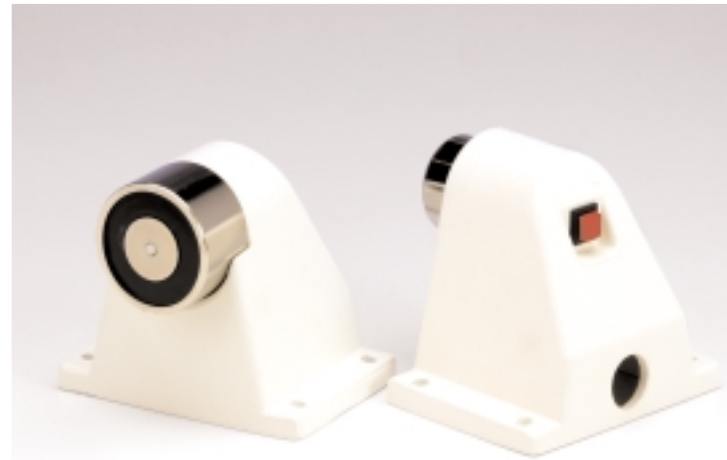

Floor Mounted door holder's are designed to hold open fire doors for ease of access and release them when an alarm is triggered. This new design is ideally suited to applications where maximum protection is needed against vandalism or accidental damage. It features a rugged cast aluminum housing, a holding magnet with integral ejection pin and a manual release switch. Cable entry can be through the base or through a 20 mm hole provided in the housing for surface mounted conduit or pyro.

Two versions are available to give 200N or 500N holding force. Every door holder is supplied complete with a door mounting keeper plate.

TECHNICAL INFORMATION

	Standard Version	High Force Version
Hold Force	200N	500N
Residual	zero	zero
Supply	24V	24V
Consumption	45mA	90mA
Finish	White painted housing, zinc plated magnet	
Weight	700g	1000g

200N Version

Part Number : 3-84-0301

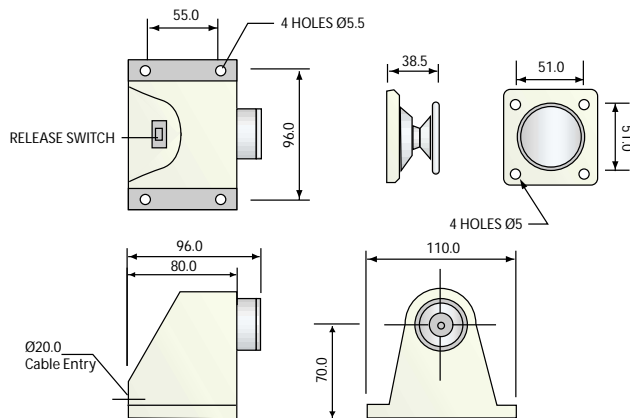

500N Version

Part Number : 3-84-0501

