

EXITGUARD EX104, EX105 & EX106 24 hour Door Alarm

The EX100 series EXITGUARD provides a simple to operate solution for the 24 hour protection of fire exit and other doors. A number of options are available that can be set up at the installation stage. The following features are standard to all EX100 series EXITGUARDS:

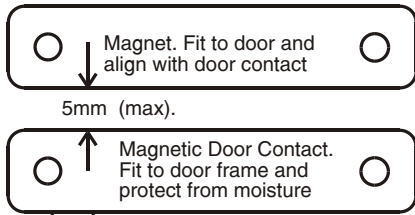

- ▶ Basic Chime repeating at 15 second intervals [1]
- ▶ Auto Reset adjustable 1 second to 90 seconds [2]
- ▶ Keyswitch Reset [3]
- ▶ Instant Alarm [4]
- ▶ Reduced alarm after 2 minutes if not reset
- ▶ Delay before alarm without pre-warn [5]
- ▶ Delay before alarm with pre-warn [6]
- ▶ Low level tamper for 2 mins then every 5 mins
- ▶ Tamper omit.
- ▶ Low battery warning on set and at 5 min intervals
- ▶ Hi & Lo level alarm tones
- ▶ LED status indicator
- ▶ Double bleep for set, single bleep for un-set.
- ▶ Pass through/ safe set facility ie set with door open

6 x AA batteries (EX104/6 versions)
Do **NOT** power from 12vdc.
This will result in damage.

Rd Bk Bl Yl
Rg Nr Bl Jn
Rt Sz Bl Gb
Ro No Bl Go

Powered from the 6 x AA batteries (supplied) EX104 or from a 12vdc intruder alarm supply EX105.

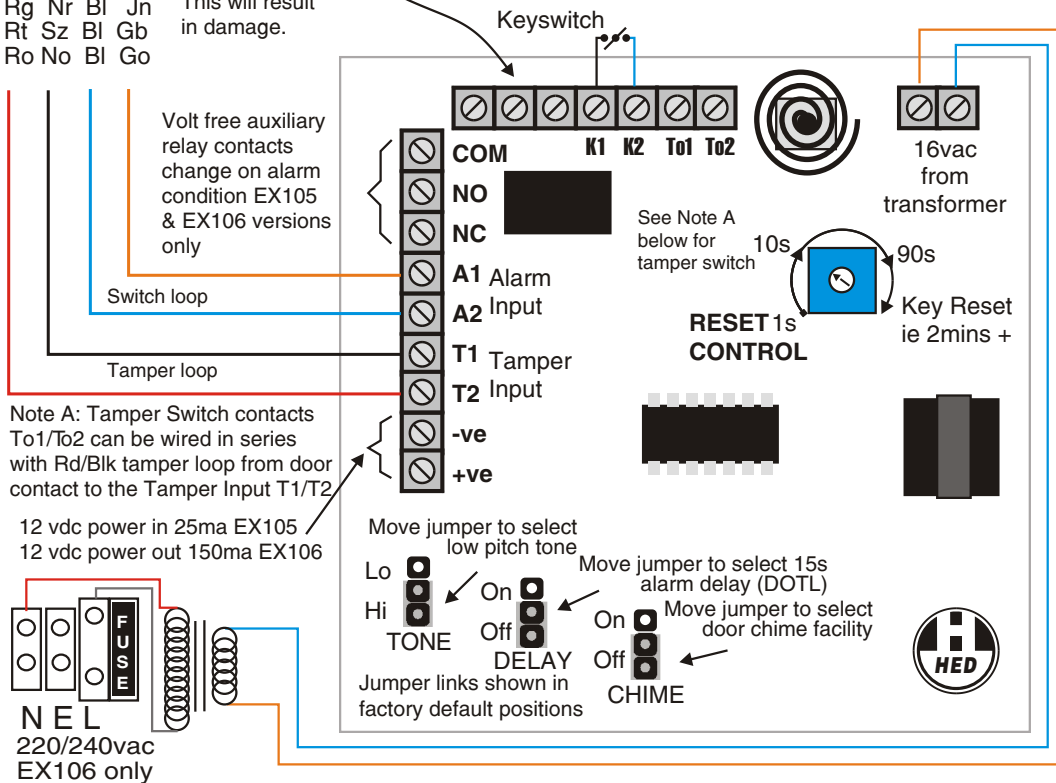

Factory Default

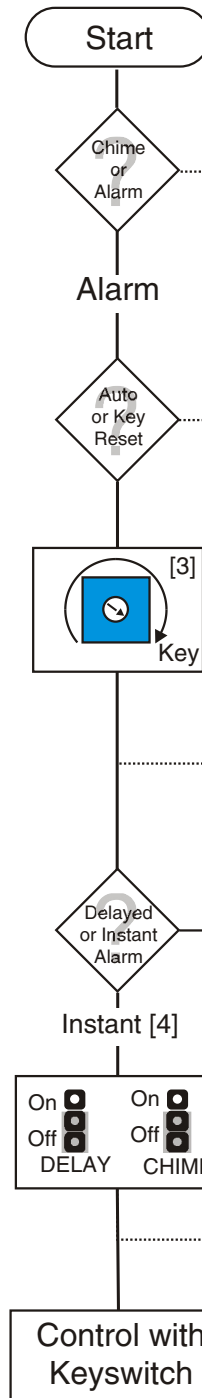

Options

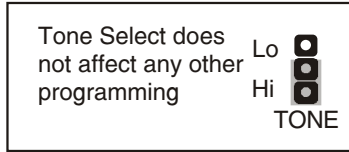

Chime [1]
Basic CHIME facility repeats at 15second intervals

Auto Reset time can be adjusted between 1 sec and 90 secs. Beyond 90 secs it becomes Key Reset

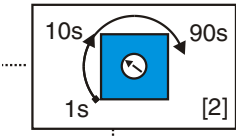

Auto reset

Turn pot fully clockwise to invoke Key Reset ie Factory default

The exact position for maximum reset time (90 secs) is approx. 2 o'clock. To determine this position exactly ensure that the door contact and the tamper loop are both open. The keyswitch should be in the O (Off) position. Apply power and switch to the I (On) position within 3 seconds. The sounder will give a bleep followed by four rapid bleeps. Turn the potentiometer slowly and observe the following:
At Key Reset a Chime & no LED
At Max Reset a Barp & no Led
Below Max Reset Silence and steady LED

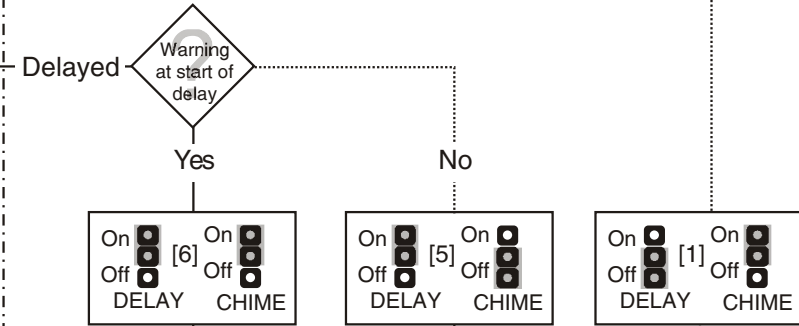

Set jumpers for desired operation

Note: There are no programming options for tamper facilities. Dwg 60095 Iss 1 Aug 2005