



Model: THS893A-HI

Thank you for purchasing our heat alarm. Please take a few minutes to read the user's manual thoroughly and familiarize yourself and your family with its operation. And save it for future reference.



SPECIFICATIONS

Main power source: 220 – 240V @ 50Hz

with 9V battery backup

Alarm volume: >85dB(A) at 3 meters

Alarm sensitivity: 54°C to 65°C

Silence time: approx. 8 minutes

Comply with: BS 5446-2:2003

Local heat alarm sound pattern:

ISO8201 (BI 0.5s - pause 0.5s - BI 0.5s - pause 0.5s - BI 0.5s - pause 1.5s, with the RED LED flash, repeat this alarm pattern)

Wired interconnection alarm sound pattern:

BI - BI - pause 1.2s, with the red LED flash, repeat this alarm pattern.

DESCRIPTION

Heat Alarms with replaceable 9V battery back-up. The alarms mount onto a wiring base. heat alarm can rapidly detect incremental temperature and absolutely meet heat level.

RECOMMENDED LOCATIONS FOR ALARMS

1. For best protection heat alarms should be installed as part of a complete fire protection system that also includes smoke alarms. Heat alarms are best suited to areas such as boiler rooms, kitchens, laundry rooms and garages where dust, fumes and moisture can cause nuisance alarms in smoke detectors. Heat alarms should not be installed in escape routes instead of smoke alarms. They should only be used in the above applications and where possible be interlinked to smoke alarms. (Smoke alarms should be installed in circulation areas forming part of escape routes and in every room in the home). The advice here follows the guidance in British Standard BS 5839-6: 2013 in general (for further information see the BS standard itself).
2. When heat alarms are installed in a room, they should be placed on the ceiling, ideally in the centre of the room. They should be at a distance no greater than 5.3m from the farthest wall no greater than 5.3m from a door to any room in which a fire might start and no greater than 5.3m from the next heat alarm NOTE: Heat alarms should not be wall mounted.
3. Closed doors and other obstructions will interfere

with the path of heat to an alarm and may prevent occupants from hearing an alarm on the other side of a closed door. Install sufficient alarms to compensate for closed doors and obstacles.

4. For further help and information on types and location of fire defection alarms refer to BS5839 pt 6 and the Fire Safety guidance given by the Department of Transport, Local Government and the Regions (DTLR).

CAUTION: Research indicates that substantial increases in warning time can be obtained with each properly installed additional alarm, It is strongly recommended that the advice in 1 above be followed to ensure maximum protection.

TWO Storey dwelling

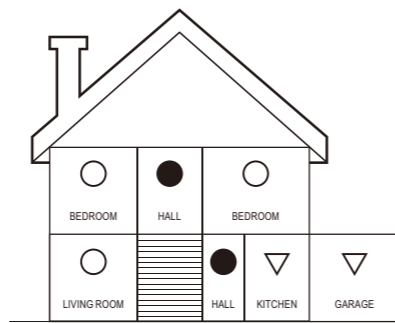

Single storey, one sleeping

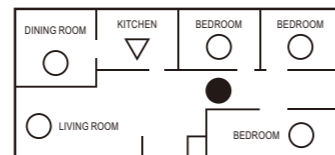

Single storey, two sleeping

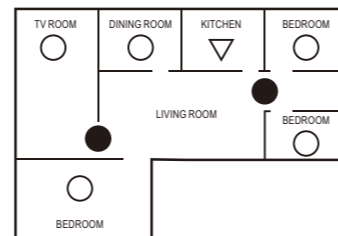

- Smoke alarms for limited protection
- Additional smoke alarms for better coverage
- ▽ Heat alarms

IMPORTANT: These heat alarms are intended primarily for use in single occupancy private dwellings. For use in other applications the manufacturers advice should be sought.

WARNING: That if there is any question as to the cause of an alarm it should be assumed that the alarm is due to an actual fire and the dwelling should be evacuated immediately.

LOCATIONS TO AVOID

DO NOT locate heat alarms:

1. In turbulent air from fans, heaters, doors, windows, etc.
2. In high humidity areas such as bathrooms and shower rooms or where the temperature exceeds 39°C (100°F) or falls below 5°C (40°F)
3. At the peak of an 'A' frame ceiling - dead air at the top may prevent smoke and heat from reaching the alarm to provide an early warning.
4. Less than 300mm (12 inches) from a wall when mounted on the ceiling.
5. In very dusty or dirty areas - dirt and excessive

dust can impair the performance of the alarm.

6. Within 300mm (12 inches) of a light fitting or room corners.
7. In locations that would make routine testing or maintenance hazardous, (e.g. over a stairwell).
8. On poorly insulated ceilings.
9. Near objects such as ceiling decorations that might impede the path of heat to the alarm.
10. Within 1500mm (5 feet) of a fluorescent light fitting. Further help and information may be found in BS5839 Part 6.

INTERCONNECTING HEAT ALARMS

- This heat alarm is capable of providing wired interconnection functions.
- Interconnecting heat alarms can be linked wired together so that if one alarm is activated then all alarms which are linked in the circuit are also sounded.
- A 9V signal is applied to the interconnect terminals between all wired interconnected Alarms.
- The maximum wiring length is 150 m between Alarms.

Wiring Diagram for Wired Interconnection Terminal

- L: Live
- E: Earth Loop
- N: Neutral
- I-Connect: Interconnect

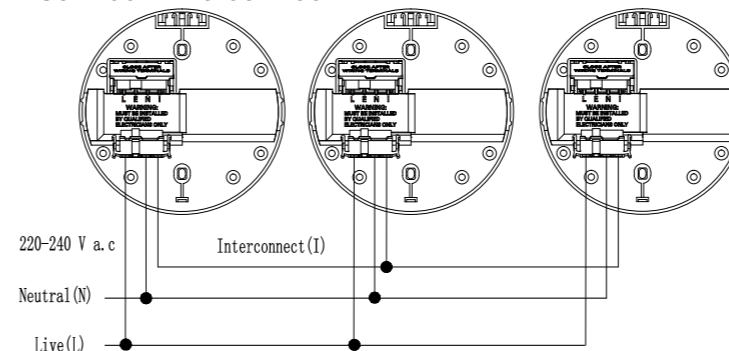

Installation - Wired connection

1. Insert the AC quick connector into the alarm back end and make sure the lock on the connector is in place as shown at Diagram 1.
 2. Ensure that the terminal cover is closed to avoid contact with the live terminals as shown at Diagram 2.
 3. Screw the mounting base onto the ceiling using the appropriate fasteners.
 4. Clip the Heat Alarm on to the base.
- Note: The Heat Alarm base will only close with a battery installed. Do not attempt to close without a battery installed.
5. Turn on the mains power and check that the Heat Alarm Green and Red LED's function:
 - a) The Green LED should illuminate to show mains power present.
 - b) The Red LED will pulse every 40 seconds to indicate correct operation and that the backup battery proves serviceable.

6. Press the Test/Hush button to check that the Heat Alarm works.
- Installation is not complete until both LEDs are functioning correctly and the alarm has been checked for correct operation.
- Wiring must be installed in compliance with local regulations.
- In the UK it is recommended that the following coloured cores are used (for example with triple flat 6243Y cable).

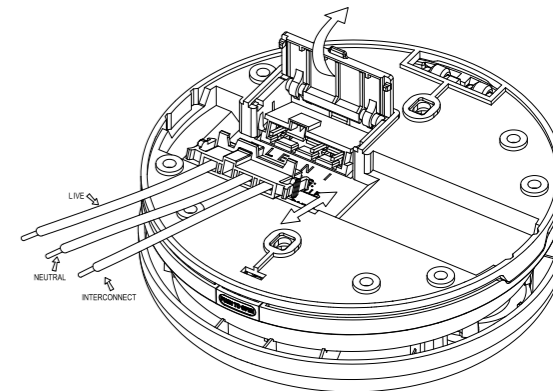

Diagram 1

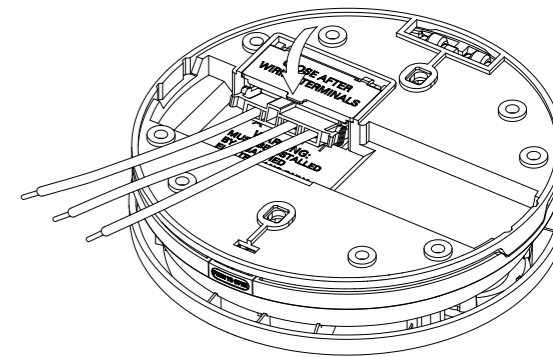

Diagram 2

CAUTION

Risk of injury and equipment damage/ malfunction

- All interconnected Heat Alarms must be supplied from the same circuit.
 - A common Neutral must be used for the Interconnect to operate.
 - DO NOT connect the Interconnect wire to Live or Neutral.
 - A maximum of 40 pcs Heat Alarms can be installed on one circuit (wired interconnection only).
 - The apparatus shall not be exposed to dripping or splashing and that no objects filled with liquids, such as vases, shall be placed on the apparatus.
- Failure to follow these instructions may result in injury and equipment damage / malfunction.**
- WARNING:** Electrical shock hazard. Disconnect the AC mains at the fuse box or circuit breaker powering the Alarm before following the cleaning instructions.
- WARNING:** Wiring should be installed by a qualified electrician in accordance with BS 7671. We advise you to follow the new harmonized cable colour coding as specified in BS 7671.

The THS 89 series heat alarm can be interconnected with TSS 89 series smoke alarm

INSTALLATION:

WARNING:

Alarm will not attach to mounting bracket unless battery is installed correctly.

WARNING:

To prevent injury, this unit must be securely attached to the ceiling in accordance with the installation instructions.

Installation sketch map

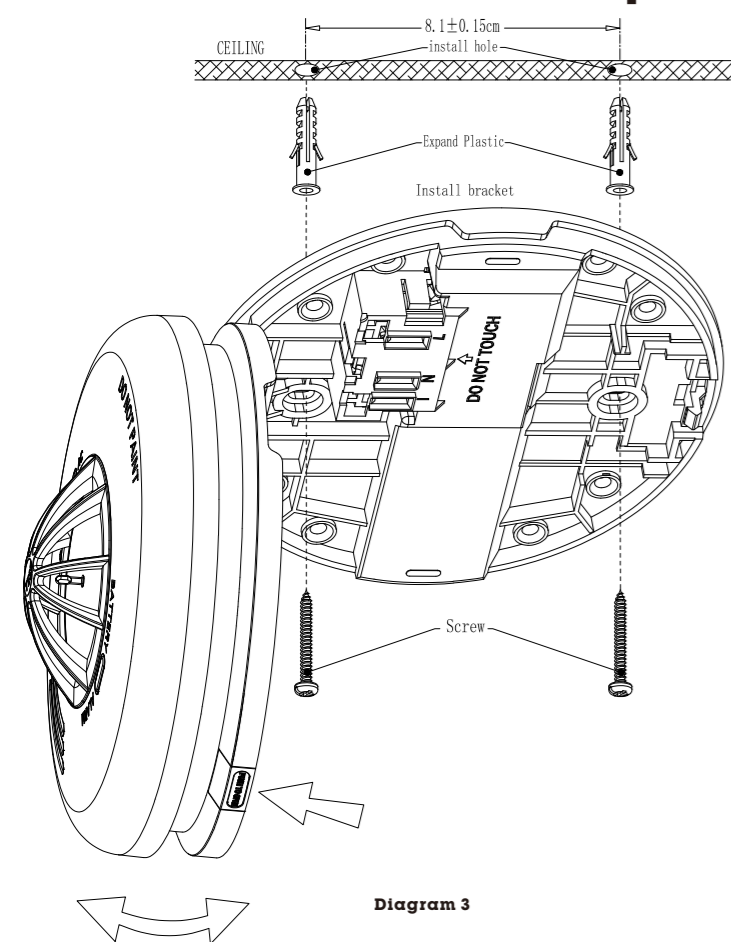

Diagram 3

OPERATION AND TESTING

TESTING:

Test by pushing the test button on the cover. This will sound the alarm if the electronic circuitry, alarm, and battery are working. If no alarm sounds, the unit has defective batteries or other failures.

DO NOT use an open flame to test your alarm, you could damage the alarm or ignite combustible materials and start a structure fire.

NOTE: WEEKLY TESTING IS REQUIRED

Normal Condition

The green LED light is always on and the red LED should flash every 40 seconds to show that the alarm is active.

Alarm Condition

When the alarm detect the high heat and sounds the audible alert, the red LED will flash one

flash/second. The flashing LED and pulsating alarm will continue until the detected temperature lower to be normal.

Low Power Pack Condition

IMPORTANT: Your heat alarm requires the power pack (9v DC battery) to have sufficient capacity of power to operate correctly.

Should your heat alarm enter a low power pack condition, the unit will emit an audible chirp once every 40 seconds. When this occurs, you must replace the battery immediately. Your heat alarm will continue to warn of this low power pack condition for approximately 30 days, however, failure to change the battery after this time would mean your heat alarm may have insufficient power to alert you in a real fire situation. After the battery is replaced, the low power warning chirp will stop.

Fault indication

The alarm chirp occurs every 40 seconds.

Alarm silence

WARNING: Before using the alarm's hush feature, fully identify the source of the heat build up and make sure that the area is safe. to activate control push and release the test/false alarm control button in the center of the alarm. the alarm will silence immediately and the red light (led) will blink approximately every 10 seconds for the next 8 minutes. this feature is to be used only when a safe condition is known to exist.

- The Hush feature will silence the alarm for approximately 8 minutes. A rapid rise in temperature will override the false alarm control and cause the unit to sound an alarm. After 8 minutes the heat alarm will revert to normal operation. If the unit still detects a dangerous situation the alarm will sound again.
- If interconnected alarms are installed, the unit that detects the high temperature and sounds the alarm cannot be inadvertently silenced by the TEST/Hush button of other units. In this case all of the alarms will continue to sound for as long as a dangerous situation is detected or until the TEST/Hush button of the initiating alarm is pressed.
- If the alarm does not go into False Alarm Control and continues to sound its alarm, the heat in the area is too high and a dangerous situation may exist - take emergency action.

BATTERY REPLACEMENT

The secondary backup power for the heat alarm is supplied by a 9V alkaline battery. The battery should last at least 5 years under normal operating conditions.

CAUTION:

Test the heat alarm for correct operation using the test facility whenever the battery is replaced.

Recommended use the following 9 v batteries for heat alarm battery replacement.

Alkaline Battery: Pairdeer 6LR61

WARNING: That batteries shall not be exposed to excessive heat such as shine, fire or the like.

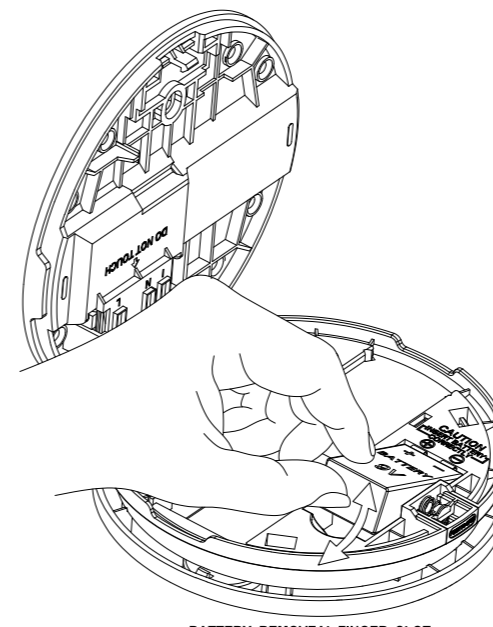

BATTERY REMOVEAL FINGER SLOT

Diagram 4

TROUBLE SHOOTING

Problem	Trouble shooting
Heat alarm does not sound when tested.	<ol style="list-style-type: none"> 1. Check that AC power is turned on. 2. Turn off power. Remove heat alarm from mounting plate and. <ol style="list-style-type: none"> a. check that connector plug is securely attached. b. Check that battery is installed correctly
The alarm chirp occurs every about approx 40 seconds, at the same time as the red LED flash once.	The battery is in low battery status, please replace battery, and refer to "replace battery" section.
Heat alarm sounds unwanted alarms.	Hire an electrician to move heat alarm to a new location. See the HEAT ALARM SITING section of this user guide.
Interconnected heat alarms do not sound when system is tested.	<ol style="list-style-type: none"> 1. Press and hold button for at least, five seconds after the first unit sounds. 2. Turn off AC power or circuit breaker and check the interconnect wiring. See INTERCNECTING HEAT ALARMS section of this user guide.

WARRANTY INFORMATION

Company warrants to the original consumer. Purchase each new heat alarm device to be free from defects in material and workmanship under normal use and service for a period of 3 years from the date of purchase. This warranty does not cover damage resulting from accident, misuse or abuse or lack of reasonable care of the product. In no case shall company be liable for any incidental or consequential damages for breach of this or any other warranty express or implied, whatsoever. The bad products can be mailed to the seller and detail the problem.

MANUFACTURER

Zhejiang Jiaboer Electronic Technology Co., Ltd
 Address: No.72, Dayantou, Tingshan Village, Dayuan Town, Fuyang District, Hangzhou City, Zhejiang Province, China
 E-mail: sales@jbe-lifepro.com
 Tel: + 86-571-63501151