

1. PRODUCT FEATURES

- Sealed in ten year battery.
- Bespoke software maximises detection ability, false alarm rejection and Alarm Silence operation.
- Power automatically switched on as alarm is installed onto its mounting plate and switched off when it is removed.
- Red LED flashes approximately every minute confirming the alarm is receiving power and ready to detect fire conditions.
- End of life low battery warning beeps once every minute.
- Low battery warning silence allows you to silence the warning at night and replace the alarm during the following day.
- Extra large test button for ease of use to test sensitivity, circuitry, battery and alarm sounder.
- Loud 85 dB piezo-electric sounder automatically resets when hazardous situation has passed.
- Alarm Silence feature allows you to silence nuisance alarms by pressing the test button, ideal in non-emergency situations. The red LED flashes every 2-3 seconds while the alarm is in the silenced mode and automatically resets in approximately ten minutes.
- Easy installation. Fixing screw kit supplied and there is no need to fit the batteries!

2. CHOICE AND LOCATION OF ALARMS

IMPORTANT NOTE: When installing heat alarms in living and working accommodation they should always be interlinked to smoke alarms and should not be used in escape routes from the building.

Heat alarms are most suitable for kitchens, boiler rooms workshops and garages where dirt and dust contaminate smoke alarms causing nuisance alarms and in some cases a failure to detect a fire early.

Photoelectric (Optical) Smoke Alarms are best for sensing smouldering fires and are therefore most suitable for rooms containing soft furnishings, carpets bedding and clothes, such as hallways, living rooms and bedrooms.

Ionisation Type Smoke Alarms are best at detecting fast flaming fires such as loose burning paper; however their operation can be significantly delayed the farther they are from the source of the fire and smoke, according to recommendations in BS5839 pt 6.

Unless there is significant risk of fast clean burning fires in a particular area, photo-electric alarms are recommended by that standard for living accommodation where most fires are started by electrical equipment and smouldering material such as soft furnishings, clothing, curtains and carpets.

For minimum protection install at least one smoke alarm in the escape route from each floor of your home and within 3 metres of all bedroom doors, see diagrams below. All alarms should be interlinked

Recommended siting of smoke and heat alarms in:

SINGLE STOREY HOME WITH ONE SLEEPING AREA

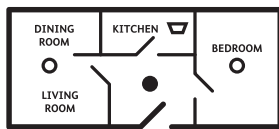

SINGLE STOREY HOME WITH TWO SLEEPING AREAS

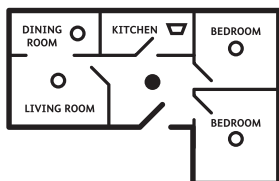

MULTIPLE STOREY HOME WITH MULTIPLE SLEEPING AREAS.

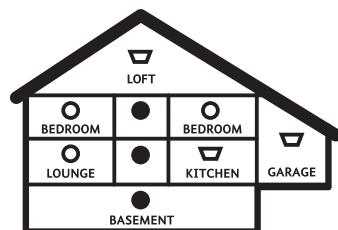

- SMOKE ALARMS FOR MINIMUM PROTECTION
- SMOKE ALARMS FOR INCREASED PROTECTION
- ◻ HEAT ALARMS

The life of the alarm can be significantly reduced by adverse environments, incorrect location and a failure to regularly clean and maintain it according to the following instructions. Incorrect location and a lack of reasonable care may also cause it to malfunction and will invalidate the warranty.

- Do not install heat alarms on walls.
- Do not locate near fans or extractors; these can pull smoke and heat away from the alarm.
- Do not install in bathroom and showers
- Do not install in rooms where the normal temperature may exceed 40°C or fall below 0°C. These may cause nuisance alarms.
- Do not install in the peak of an A frame or sloping ceiling; this may delay heat reaching it due to still air.
- Do not install less than 300mm from walls and beams due to still air.
- Do not install less than 300mm from light fittings.
- Do not install heat alarms in sleeping areas such as bedrooms, nurseries, playrooms or areas where the elderly and disabled may spend long periods of time.
- Do not install on poorly insulated ceilings where cold air boundary layers may delay heat from reaching the alarm.
- Do not install near objects that may delay or prevent heat from reaching the alarm.
- Avoid installing within 1500mm of fluorescent light fittings that could cause nuisance alarms.
- Do not paint the alarm.
- The location of alarms must be in accordance with Part B of the applicable Building Regulations. Further help and guidance can also be found in BS5839 Part 6.

WARNING: Do not store alarms in temperatures below 5 degrees and above 30 degrees, and in low humidity; this may cause beeping and nuisance alarms when first installed. These will clear after a short time when the alarm has become acclimatised. Extended periods under these conditions will reduce the life of the alarms and invalidate the warranty.

Further Information on Alarm Location

- At least one SMOKE alarm should be installed in the escape route from all floors of the building.
- The detection element of the heat alarm should be between 25mm and 150mm below the ceiling.
- Heat alarms should be mounted at least 300mm from any wall or light fitting.
- Heat alarms should NOT be mounted on walls.
- Do not use heat alarms in escape routes.
- No heat alarm should be further than 5.3 metres from other heat or smoke alarms.
- To give the earliest warning of a developing fire all smoke and heat alarms in your home should be interlinked.

Recommended position of alarms in a room, corridor or escape route:

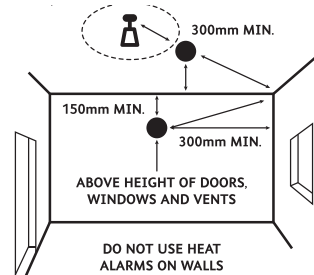

Recommended position of alarms on apex ceilings:



3. INSTALLATION PROCEDURE

Separate the alarm from the mounting plate. The product is shipped with the batteries switched off and the mounting plate loose. (Attaching the baseplate and rotating it turns the alarm on.) If it has been activated prior to installation, depress the security tag shown below and twist the alarm anti-clockwise while holding the mounting plate.

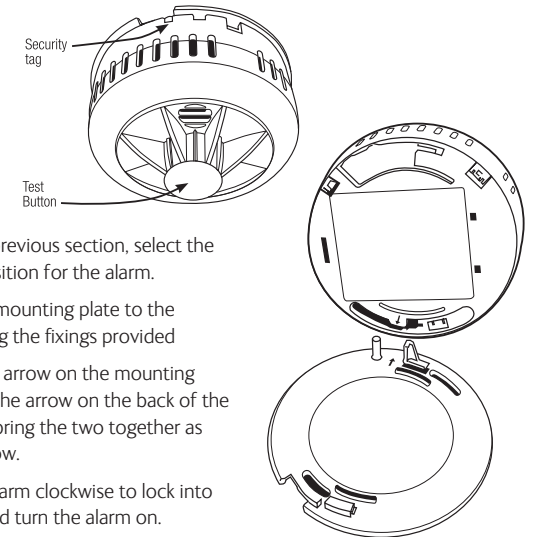

- Using the previous section, select the desired position for the alarm.
- Screw the mounting plate to the ceiling using the fixings provided
- Line up the arrow on the mounting plate with the arrow on the back of the alarm and bring the two together as shown below.
- Twist the alarm clockwise to lock into position and turn the alarm on.

Testing the alarm

Press and release the test button to test the alarm. It should sound three times with a flashing red LED then stop. After the test make sure the red LED flashes about once every minute. Test the alarm once a week to ensure correct operation.

WARNING: The electronic test button provides a full test of the alarms functionality. Do not try to test it using heat or a naked flame; this will damage the alarm and invalidate the warranty

Interlinkable alarms. Maximum 15

If you wish to interlink smoke and heat alarms, use the wireless FHH10W heat alarms and the FHB10W smoke alarms available from Fireblitz.

4. USER INFORMATION

Protect your Home Against Fire

Contact your local Fire Brigade for a home safety check, this information is free and will identify potential fire hazards in and around your home.

Make sure all occupants of the home know what a fire alarm sounds like. Prove and practise a fire escape plan and arrange a suitable and safe assembly point.

What to Do if the Alarms Sound

Alarms sounds are as follows:

Full alarm indicating smoke and fire	Repeating series of 3 beeps every 4 seconds with flashing light	••• ••• ••• •••
Low Battery	Single beep every minute	• • • •
Test button jammed	One beep every 11 seconds	• • • •
Fault	Double beep every minute	•• •• •• ••

Ensure everyone leaves the building as soon as possible.

- Do not run.
- Do not stop to collect belongings.
- If it is safe to do so, close all windows and doors as you escape to prevent the spread of fire.
- Smoke is the main cause of death from fire. If trapped inside the building, cover your mouth, conserve breath and crawl to safety.

Do not silence a fire alarm until you know the cause of the alarm and when all occupants are safely outside the building. The light on the test button of the alarm that has set the system off will be flashing Red once every second. The system can only be silenced from this alarm. The lights on the other alarms will be flashing once every minute.

5. ALARM MAINTENANCE

A regular program of fire alarm maintenance will help to keep your alarm in good working order.

- Test the alarms weekly making sure that all interconnected alarms in the system sound within 10 seconds.
- Vacuum the alarms every six months and wipe them with a damp cloth.
- Do not paint the alarm.

A fire alarm is a sensitive life-saving device. The life of this alarm can be significantly reduced by adverse environments, incorrect location and a failure to regularly clean and maintain it according to these instructions. Incorrect location and a lack of reasonable care may also cause it to malfunction and will invalidate the warranty.

6. TROUBLE SHOOTING

The battery will last 10 years and is not replaceable. At the end of its life the alarm will beep once every minute for a minimum of one month.

The life of the battery can be significantly shortened by periods of storage or use in temperatures below 5 °C or above 30 °C. It will also be shortened by frequent or extended periods in full alarm often caused by conditions such as cigarette smoke, steam, aerosol spray and condensation. In these circumstances the warranty will be void.

If this happens at night you can press the test button to silence the battery warning for 10 hours. Replace the alarm as soon as possible.

Problems are indicated in five ways;

1. The alarm beeps twice every minute indicating a malfunction.
2. The alarm beeps once every minute indicating a low battery.
3. The full alarm sounds for no reason. (A repeating series of three beeps with flashing light)
4. The alarm does not sound when pressing the test button.
5. The test button light remains steadily on or off. (i.e. does not flash approximately once every minute, when the unit is not in alarm)

Inspect for obvious damage. Check that the alarm has been installed in accordance with the instructions. In the case of repeated nuisance alarms, check that it is free from dust, cobwebs and external contamination from such things as cigarette smoke, drying paint, spray from household aerosols and steam that will ultimately shorten the life of the alarm and invalidate the warranty.

If this does not correct the problem, do NOT attempt to repair. There are no user serviceable parts internally. If the smoke alarm is within the warranty period and terms, indicate the nature of the problem and return the unit with proof of purchase to the address at the end of this manual. Units beyond warranty cannot be economically repaired.

9. PRODUCT WARRANTY

Fireblitz guarantees to you, as a purchaser, that the enclosed fire alarm will be free from defects in material, workmanship or design under normal use and service for a period of 10 years.

This Guarantee is not assignable. Our liability to you, under this guarantee is limited to repairing or replacing any part which we find to be defective in material, workmanship or design, free of charge to the customer, upon sending the alarm with proof of date of purchase, postage paid to Fireblitz Extinguisher Ltd, Units 15/17 Manford Industrial Estate, Manor Road, Erith, Kent DAB 2AJ. The terms of this guarantee will not apply in the following circumstances: If the alarm has been modified, dismantled, contaminated, damaged, neglected or otherwise abused or altered following the date of purchase, or if it fails to operate due to incorrect siting, installation, maintenance or inadequate or over voltage AC electrical power, or damage caused by failure to abide by the instructions supplied. It is specifically drawn to the users attention that substantial periods in alarm will shorten alarm life, during which time the fire alarm will have provided valuable protection; no Claim under the guarantee will be entertained.

The liability of Fireblitz Ltd, arising from the sale of this alarm or under the terms of this guarantee shall not in any case exceed the cost of replacement of the alarm. In no case, shall Fireblitz Ltd be liable for consequential loss or damage resulting from the failure of the alarm or the breach of this or any other guarantee, express or implied or for damage caused by failure to abide by the instructions supplied.

This guarantee does not affect your statutory rights.

Fireblitz Extinguisher Ltd.

Units 15-17 Manford Industrial Estate, Manor Road. Erith, Kent DA8 2AJ

Telephone: 01322 342238

TECHNICAL HELPLINE 0800 008 6568

or Text on 07885 831239

Email: customerservices@fireblitz.co.uk



Fireblitz Extinguisher Ltd
15

BS 5446-2: 2003 KM 654703

For Technical Data see product handbook

Firehawk
SAFETY PRODUCTS

FEATURING
**Advanced
THERMISTOR
Protection**

10 YEAR BATTERY OPERATED

Heat Alarm

MANUAL



BS 5446-2: 2003
KM 654703

FHH10

READ AND RETAIN THIS USER MANUAL