

STI STOPPER®

STI STOPPER

Protective cover to help stop malicious or accidental false fire alarms.

This unique device has been helping stop false fire alarms around the world for decades, without restricting legitimate operation of devices such as fire alarm break glass call points. Ideal for schools, colleges, hospitals, nursing homes, hotels and all public buildings where there is a history or a threat of false fire alarms.

HOW IT WORKS

The Stopper consists of a clear, tamper-proof, tough polycarbonate cover and frame that retrofits over the break glass call point. When lifted to gain access to the break glass, its optional battery powered integral sounder emits a piercing 96dB (at 1 metre). Immediate attention is drawn to the area and a prankster will either run or be caught.



STI 6530	Stopper flush mounted without integral sounder
STI 6531	Stopper surface mounted without integral sounder (includes 30mm spacer)
STI 6532	Stopper flush mounted with integral sounder
STI 6533	Stopper surface mounted with integral sounder (includes 30mm spacer)

ACCESSORIES

STI 6503	30mm spacer (supplied with STI 6531 & STI 6533)
STI 6504	50mm spacer
STI C024	Backplate (for irregular surfaces)
STI/BS	Breakable seals (pack of 10)
E009	Deactivation pin

OPTIONS

COLOURS AVAILABLE For Green, Blue or Yellow add /G/B or /Y

ADDITIONAL SECURITY For break seal add /BS. For lock add/L

EXAMPLE STI 6533/G/BS = Green Stopper, surface mounted with sounder and break seal facility.

STI 6530/BS = Red Stopper, flush mounted without sounder but with break seal facility.

NB: The Stopper is supplied in red and with the operating instructions IN CASE OF FIRE – LIFT COVER BREAK GLASS
Alternative and custom markings are available



STI Stopper Colours Available



STI Break Seal

Part Numbers

Features

- Constructed from tough clear polycarbonate
- Protects equipment from accidental operation, vandalism, product misuse, dust and weather
- Available with or without integral sounder. Integral sounder powered by a 9V PP3 battery (included)
- Optional 12 or 24 VDC powered units
- Available for flush or surface mounted products
- Lock or break seal options for added security
- Optional depth spacers to accommodate a wider variety of products
- Cover backed by a lifetime guarantee against breakage in normal use
- Polycarbonate tested -40°F (-40°C) to 120°F (49°C)
- Easy to install, can retrofit over existing device



Safety Technology International (Europe) Ltd
Unit 49G Pipers Road • Park Farm Ind. Est. • Redditch • Worcestershire • B98 0HU • England
Telephone: 44 (0) 1527 520 999 • Fax: 44 (0) 1527 501 999
Email: info@sti-europe.com • Web: www.sti-europe.com

Dimensions and Technical Information

Installation Instructions

- Position the Stopper frame centrally over the device to be protected, and mark the position for the four fixing screws.
- Drill the holes, assemble the frame and hinge mechanism and fit the Stopper with the wall fixings and screws provided.
- If a surface spacer is included, ensure that the plastic lip of the spacer is pointing upwards. This will provide a base for the hinge (see diagram below).
- Ensure the deactivation pin is removed from the alarm unit on those fitted with integral sounder. The pin should be retained, in the event any maintenance work is carried out.
- The surface spacer provides cable entry facilities for conduit, cable and trunking. A 30mm depth spacer is supplied as standard. An optional 50mm spacer is available.
- Where an optional weather gasket is positioned between the Stopper frame and spacer. Ensure the adhesive side of the weather gasket is fixed to the spacer and not the Stopper frame.
- To replace the 9V PP3 battery in the alarm unit, replace the deactivation pin, remove the two screws on the underside of the alarm unit and replace battery. Re-assemble ensuring to remove the deactivation pin. The pin should be retained.

Important Notice

Instructions should be provided to avoid the unlikely possibility that persons, in the event of a real fire, lift the Stopper cover and think they have set off the fire alarm. All personnel should be reminded that the Stopper is a protective cover and it is necessary to lift the cover and "Break The Glass" in the case of a real fire.

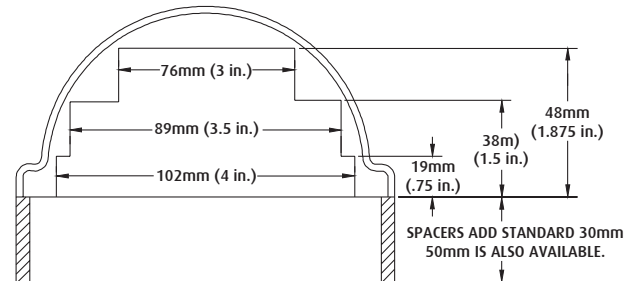

DEPTH CHART FOR THE STOPPER

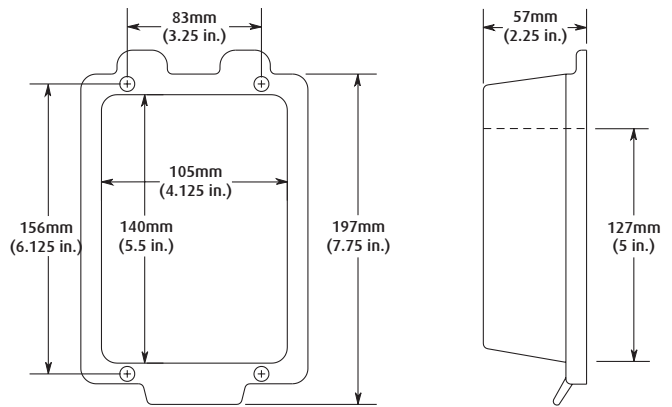

FRONT VIEW

SIDE VIEW

