

# STI 8-Channel Receiver

Model: STI-34108

Thank you for purchasing this fine product. Your satisfaction is very important to us. Please read this manual carefully to get the most from your new product.

## HOW THE PRODUCT WORKS

STI offers multiple wireless products designed to alert you of several different conditions. The STI 8-CHANNEL RECEIVER is a 433 MHz radio signal receiver that allows you to monitor up to 8 different STI devices at a single, convenient location. When placed in enroll mode, it allows you to select 1 of 8 different zones that will represent your STI device(s) best, and enrolls it when the monitor detects the STI device's wireless signal. The STI wireless device family uses a system that also ensures other devices (not from STI) are not enrolled or detected. There are no concerns of accidental enrollment, alerts or crosstalk. The RECEIVER allows you to choose which devices shall have a latching memory condition, when selected during enrollment. It also allows you to select turning on a siren, sounding a chime, triggering a normally open or normally closed switch or turning on an external 12 VDC output. The STI 8-CHANNEL RECEIVER also acts as a console repeater when paired with other STI 8-CHANNEL RECEIVERS to receive wireless transmissions in up to 4 other areas over long distances or around disruptive terrain.

## BEFORE YOU START

Refer to this drawing to become familiar with all the parts.

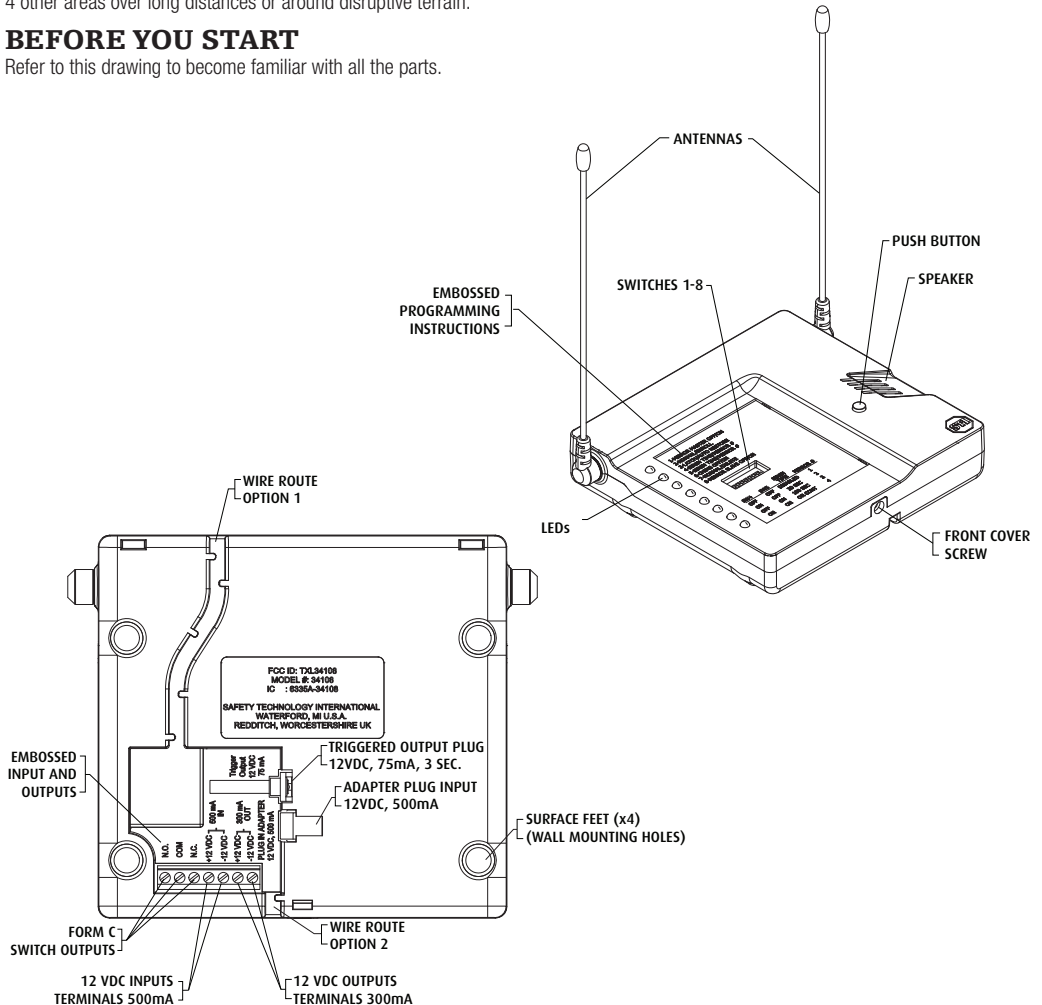

# INSTALLATION GUIDE

## Surface Installation:

1. Ensure mounting screws are removed.
2. Insert rubber feet (provided) into holes on bottom cover.
3. Route wires under the product.

## Wall Mounted Installation:

1. Ensure rubber feet are removed.
2. Remove front cover screw.
3. Remove cover (be careful not to lose push button).
4. Mark mounting holes on wall using bottom cover as template.
5. Drill holes with 3/16" drill bit.
6. Insert wall anchors (provided).
7. Insert power cord and wires and route on the back.
8. Insert mounting screws (provided) into plastic washers (provided).
9. Insert mounting screws into PCB holes through back of cover.
10. Insert mounting screws into wall anchors and tighten.
11. Press fit push button onto the push button switch on the circuit board.
12. Insert top cover tabs into bottom cover slots.
13. Carefully close top cover ensuring the push button inserts into cover hole and antennas rest in the side cover grooves.
14. Insert front cover screw and tighten.
15. Plug in AC adaptor.

If using for the first time or for enrollment adjustments, follow **Zone Enrolling** instructions. Otherwise, STI 8-CHANNEL RECEIVER should be fully functional.

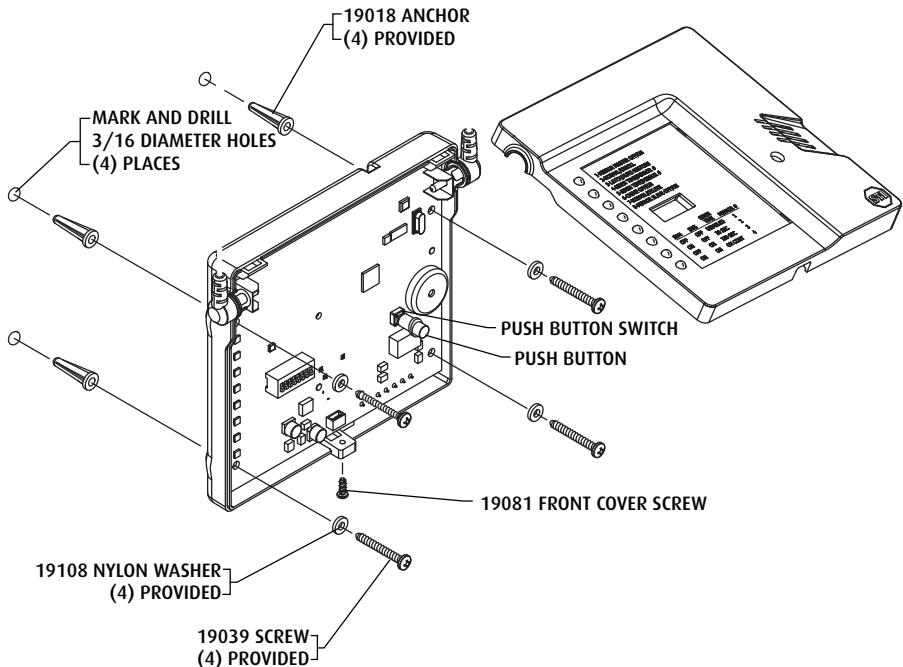

## COMPONENT DESCRIPTIONS (Top Side):

**Switches (1- 8)** - For reference, information is also written on the RECEIVER case (located under Zone ID list).

1 - MIRROR MASTER OFF/ON	5 - SIREN TIME/MIRROR#
2 - NORMAL/ENROLL	6 - CHIME OFF/ON
3 - AUTO RESTORE/LATCH	7 - NORMAL/DELETE
4 - SIREN TIME/MIRROR#	8 - MIRROR SLAVE OFF/ON

SW4	SW5	SIREN TIME	MIRROR #
OFF	OFF	DISABLED	1
ON	OFF	30 SEC	2
OFF	ON	180 SEC	3
ON	ON	ON CONT	4

Switch #	DESCRIPTION	ON (Switch UP)	OFF (Switch DOWN)
<b>SW1</b>	MASTER RECEIVER SETTING (Only active when SW8 = ON)	ENABLED Switch on only for Mirror Master	DISABLED Switch off if not Mirror Master
<b>SW2</b>	ENROLL DEVICES	ENABLED LED for zone number waiting to enroll blinks. Button used to change zone to be enrolled.	DISABLED Normal Operation
<b>SW3</b>	ALARM LATCHING (Only active while SENSOR is being enrolled)	ENABLED LED turns on when triggered Button press turns off siren LED flashes when restored Second button press turns off LED flashing	DISABLED LED turns on when triggered  LED turns off when restored
<b>SW4</b> and <b>SW5</b>	RECEIVER # / SIREN TIME  ON = 1 OFF = 0	RECEIVER# (when SW8 = ON)  (SW4)(SW5) 00 = Mirror #1 10 = Mirror #2 01 = Mirror #3 11 = Mirror #4	SIREN TIME (when SW8 = OFF) Note: Siren can turn off upon button press. (SW4)(SW5) 00 = 0 Second (Silent) 10 = 30 Seconds 01 = 180 Seconds 11 = Continuously ON
<b>SW6</b>	RECEIVER CHIME	ENABLED Chime sounds a double beep when device is triggered.	DISABLED Chime does not sound when device is triggered.
<b>SW7</b>	DELETE DEVICES	ENABLED All LEDs turn red. LED blinks for zone to be deleted. Hold button for 5 seconds to delete. Hold button another 5 seconds to delete all.	DISABLED Normal Operation
<b>SW8</b>	MIRROR MODE	ENABLED Enables Mirror Mode. Enables SW1. SW4/5 indicate RECEIVER#. Turns on RECEIVER# (SW4/5) transmissions.	DISABLED Disables Mirror Mode. Disables SW1. SW4/5 indicate ALARM TIME. Turns off mirrored transmissions.

**Push Button** - Selects zone to enroll or delete, acknowledge latched alert (resets LED to GREEN), silences alarm.

**LEDs (1- 8)** - Each enrolled SENSOR or mirrored RECEIVER has an LED that indicates the current state of that zone from the top LED (Zone 1) down to the bottom LED (Zone 8). The zone states, in order of precedence, are:

- LED RED = zone alarm
- LED RED (flashing) = zone latched (zone was in alarm and returned to normal)
- LED AMBER = SENSOR trouble (battery or SENSOR tamper trouble detected)
- LED GREEN = zone normal
- LED off = zone not enrolled

**Sounder** - Audio feedback for siren, chime/ beeps, zone enrollment and deletion.

## COMPONENT DESCRIPTIONS (Bottom Side):

**Adapter Plug Input** - Input connector 12VDC, 500mA, center positive adapter (provided).

**Triggered Output Plug (75mA)** - 12VDC output connector. Activates with 12VDC, 75mA for 3 seconds when any zone is triggered.

### **Form C Switch Outputs (Dry Contacts) 30VDC, 1A Resistive**

**N.O.** - Normally open circuit to COM terminal. Closed to COM when alarm is triggered.

**COM** - Common return between N.O. or N.C.

**N.C.** - Normally closed circuit to COM terminal. Open to COM when alarm is triggered.

When any zone has an alert signal received and the LED changes to continuous RED, a short circuit is made between the NO and COM, and an open circuit is made between NC and COM. As soon as ALL zones are not in alert mode and the LED is no longer continuous RED, an open circuit is made between NO and COM, and a short circuit is made between NC and COM.

### **12VDC Input (500mA)**

**+12VDC** - Positive voltage input. Power input circuit rated to 500mA current.

**-12VDC** - Negative voltage input.

The 12VDC input terminals allow the RECEIVER to be powered from an external 12VDC, 500mA rated power source.

### **12VDC Output (300mA)**

**+12VDC** - Positive output voltage. 300mA maximum output current.

**-12VDC** - Negative output voltage.

A continuous 12VDC output is produced only while sounder is activated. The 12VDC output terminals will turn on at the same time as the onboard sounder in siren mode or chime mode.

## NORMAL OPERATION

The RECEIVER receives 433 MHz radio signals from numerous STI sensors enrolled to the RECEIVER. It provides feedback in the form of LED colors, onboard sounder annunciation, onboard sounder siren, switched on or off output terminals (Form C contacts), a 3 second 12 VDC @ 75mA max. output on the triggered output plug and 12 VDC output terminals powered at the same time as the onboard sounder.

### **LED Operation:**

The LED status with higher importance is emitted by the LED. The LED importance is as follows (highest to lowest):

- Red LED - Zone enrolled, Alert status
- Flashing Red LED - Zone enrolled, Latched and Non-Triggered status
- Amber LED - Zone enrolled, Tamper Alert and Non-Triggered status
- Green LED - Zone enrolled, Normal and Non-Triggered status
- LED OFF - Zone not enrolled

### **Onboard Sounder Operation:**

**Siren Mode** – SW4 and SW5 (settings)

The onboard speaker gives a 4 KHz @ 90dB sound for the SIREN TIME set by SW4 and SW5 when any zone's alert signal is received (see **Component Descriptions for siren times**).

**NOTE:** Chime/Beep mode must be turned off, (SW6 OFF), for the siren mode to activate.

**Chime/Beep Mode** – (SW6 ON)

The onboard speaker gives a double beep when any zone's alert signal is received. Chime/Beep mode overrides the siren mode.

### **Sensor Operation:**

A SENSOR sends a 433 MHz radio signal to the RECEIVER that will indicate one or more of the following: Alert triggered; restored to normal; sensor tampering; low battery; lost signal.

### **Low Battery / Tamper Detection / Out of Range SENSOR Alerts:**

If the battery is too weak, something has triggered a tamper alert signal from the SENSOR, or the SENSOR has been out of range between 12 - 24 hours, the zone LED will light AMBER to alert a need for attention to that device.

## **ZONE ENROLLING AND DELETING PROCEDURES**

The STI 8-Channel Receiver is designed to receive ONLY wireless signals from products in the *STI Alert Series* (see back of the installation instructions). The RECEIVER allows you to enroll up to 8 devices into zones 1 thru 8. The RECEIVER will enroll from different SENSORS directly or by enrolling other mirrored RECEIVERS.

When ENROLL mode is enabled (SW2 ON), the LEDs for any currently enrolled zones will turn RED to indicate these zones are not available. The LED will flash GREEN to indicate the available zone to be enrolled. Press the push button to change to a different zone to be enrolled. The next available zone will have the flashing GREEN LED. The RECEIVER will not allow enrollment into an occupied zone. The RECEIVER will not allow the same device to be enrolled into more than one zone.

The RECEIVER will not enter ENROLL mode while it is in DELETE mode (i.e. DIP SW7 ON).

### **Zone Latching:**

"Latching" lets you know a zone alert was previously triggered but the alert has also been cleared. When a zone is in the "latched" status, the zone LED will flash RED. For example, when a door SENSOR has been opened and closed, the zone LED will flash RED to indicate the door was opened previously, but is no longer opened.

The latching is released when the user presses the push button to indicate acknowledgement of the alert. When the "latched" status is released, the zone LED will change back to continuous GREEN. If the zone has another alert before the "latched" status is released, the LED will change to continuous RED in the alert state, and then back to flashing when the alert is cleared.

A zone will have "latching" when SW3 is (ON) at the time of enrollment. If zone latching is not selected at the time of enrollment (SW3 OFF), the zone LED will change from continuous RED back to continuous GREEN when the alert has been cleared.

## **Enrolling Sensors into Zones:**

1. Check that the module is not in DELETE mode (SW7 OFF).
2. If the zone should have "latching" set (SW3 ON).
3. Enable ENROLL mode set (SW2 ON).
4. Check that the zone flashing GREEN is correct, and note the zone(s) with RED LEDs.
5. Change the status of the SENSOR to be enrolled by triggering an alert on the SENSOR and return it to the non-triggered state (if done manually).
6. The RECEIVER will give a double beep and the zone LED will change to continuous RED.
7. Repeat steps 2-6 to enroll another SENSOR.
8. To exit ENROLL mode set (SW2 OFF).

### **Sensor Installation Tip:**

When first enrolling a SENSOR, set the "latching" on (SW3 ON), and bring the SENSOR to the RECEIVER location to enroll it before mounting the SENSOR. Then, mount the SENSOR at its intended location and trigger an alert on the SENSOR. Check the zone on the RECEIVER to see if it is continuous RED or flashing RED, which means it received the SENSOR'S signal. Then, if latching is not desired, delete that zone (see **Deleting Single Zones**) and enroll the SENSOR again without latching (SW3 OFF), from the mounted location.

## Mirrored Receiver Operation:

The LEDs, the sounder, the siren time and the 12VDC output activation will duplicate the sensor settings enrolled on the master RECEIVER. If a sensor is enrolled to a mirrored RECEIVER instead of the master, a transmission from the master RECEIVER will override the mirrored RECEIVER'S LED status.

## Enrolling Mirrored (multiple) Receivers:

The LEDs, the sounder, the siren time and the 12VDC output activation will duplicate the sensor settings enrolled on the master RECEIVER. If LED "latching" is desired on the mirrored RECEIVER, this must be selected at the time of the mirrored RECEIVER'S enrollment.

**NOTE:** If a SENSOR is enrolled to a mirrored RECEIVER in error (instead of the master), a transmission from the master RECEIVER will override the mirrored RECEIVER'S LED status.

1. Check that the module is not in DELETE mode (SW7 OFF).
2. Use SW4 and SW5 to select the mirror number 1-4 if not the master (see **Component Descriptions**).
3. Enrolling mirrored RECEIVERS is performed in sequential pairs:

Pair	Column A		Column B
1	Master	=>	Receiver 1
2	Receiver 1	=>	Receiver 2
3	Receiver 2	=>	Receiver 3
4	Receiver 3	=>	Receiver 4

**NOTE:** All SENSORS are enrolled only to the master RECEIVER. The mirrored RECEIVERS copy the master RECEIVER'S output (except latch settings) sequentially thru RECEIVERS 1 - 4.

4. Set SW1 and SW8 (ON) on the master RECEIVER.
5. Set SW8 (ON) on each mirrored RECEIVER.
6. Enable ENROLL mode, SW2 (ON), on the two RECEIVERS being paired together.
7. Press and release the Push Button on the Column A RECEIVER (above). The Column B receiver will give a double beep.
8. Press and release the Push Button on the Column B RECEIVER (above). The Column A RECEIVER will give a double beep.

**NOTE:** If Column B RECEIVER was previously enrolled to Column A RECEIVER and was not deleted, the Column A RECEIVER will not double beep, but will work properly.

9. Disable ENROLL mode, SW2 (OFF), on both RECEIVERS.
10. Press and release the Push Button of the Column A RECEIVER (above). The LED's of the Column B RECEIVER will light in the same configuration.

## Enrolling Sensors into Master + Mirror Receiver Systems (with or without latching):

When using a master + mirror RECEIVER system, the latching feature is set independently on the master and/or mirror RECEIVERS. Latching on the master and/or mirrored RECEIVERS is only set for a zone at the time the SENSOR is enrolled into the master RECEIVER. You will need to set (SW2 ON) and (SW3 ON or OFF) for each RECEIVER at the time of SENSOR enrollment.

1. Check that each RECEIVER is not in DELETE mode (SW7 OFF).
2. Set desired "latching" on each system RECEIVER. A RECEIVER set to (SW3 ON) will have latching. The RECEIVER set to (SW3 OFF) will only indicate the zone status.
3. Set each RECEIVER to ENROLL mode, (SW2 ON), that will store the latch setting.
4. Check that the zone flashing GREEN on the master RECEIVER is correct, and note the zone(s) with RED LEDs.
5. Trigger an alert on the SENSOR being enrolled and return it to the restored state (if restore is triggered manually).
6. The RECEIVER will give a double beep and the zone LED will change to continuous RED.
7. Repeat steps 2-6 to enroll another SENSOR.
8. To exit ENROLL mode, set (SW2 OFF) on the master RECEIVER.
9. Set all master and/or mirror RECEIVERS (SW3 OFF).

## System Examples

### SINGLE SYSTEM

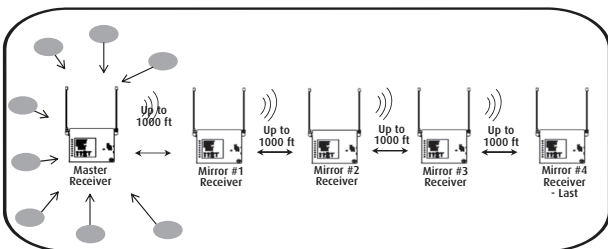

### MULTIPLE SYSTEMS

● Represents any STI 433 MHz sensor transmitting ONLY to a Master Receiver

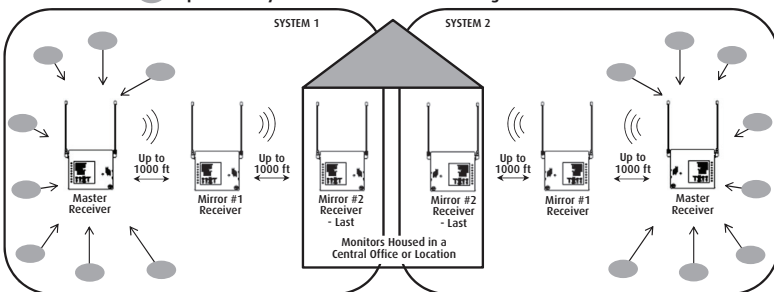

## DELETING SINGLE ZONES (Sensors):

1. Enter DELETE mode (SW7 ON). All enrolled zone LEDs will turn RED. The first zone to be deleted will have the LED flashing RED.
2. Press and release the push button to cycle the flashing LED through the zones until it reaches the zone to be deleted.
3. Press and hold the push button for 5 seconds to delete the zone with the flashing LED. The RECEIVER will give a single beep and the LED will turn off. Release the push button.

## DELETING ALL ZONES (Sensors and Mirrored Receivers):

You must delete all zones in order to delete keyfobs and/or a mirrored RECEIVER.

1. Enter DELETE mode (SW7 ON). All enrolled zone LEDs will turn RED. The first zone to be deleted will have the LED flashing RED.
2. Press and hold the push button for 5 seconds. The RECEIVER will give a single beep and the flashing LED will turn off. Continue to hold the push button.
3. After the first zone is deleted and while still holding the push button, all other enrolled zones will flash for 5 seconds. The RECEIVER will give a double beep and all of the LEDs will turn off when those zones are deleted.

## IMPORTANT NOTICE:

This product has been tested and complies with the specifications for a Class B digital device, pursuant to Part 15 of the FCC Rules. These limits are designed to provide reasonable protection against harmful interference in a residential installation. This equipment generates, uses, and can radiate radio frequency energy and, if not installed and used according to the instructions, may cause harmful interference to radio communications. However, there is no guarantee that interference will not occur in a particular installation. If this equipment does cause harmful interference to radio or television reception, which is found by turning the equipment off and on, the user is encouraged to try to correct the interference by one or more of the following measures:

- Reorient or relocate the receiving antenna
- Increase the separation between the equipment or devices
- Connect the equipment to an outlet other than the receiver's
- Consult a dealer or an experienced radio/TV technician for assistance

Operation is subject to the following two conditions: (1) this device may not cause interference, and (2) this device must accept any interference, including interference that may cause undesired operation of the device.

Changes or modifications not expressly approved by Safety Technology International, Inc. could void your authority to operate this equipment.

To reduce potential radio interference to other users, the antenna type and its gain should be so chosen that the equivalent isotropically radiated power (e.i.r.p.) is not more than that permitted for successful communication.

This product meets the applicable Industry Canada technical specifications. Le present materiel est conform aux specifications techniques applicables d'Industrie Canada.

Model: 34108      FCC ID: TXL34108      IC: 6335A-34108

## WARNINGS

**FOR INDOOR USE ONLY. Keep RECEIVER away from water and/or damp areas.**

## WARRANTY INFORMATION:

Safety Technology International, Inc. warrants to the **original** consumer/purchaser that this product shall be free of defects in material and workmanship under normal use and circumstances for a period of one (1) year from the original date of purchase.

## ACCESSORIES

STI-34401	Wireless Universal Alert Sensor
STI-34104	4-Channel Receiver
STI-34108	8-Channel Receiver
STI-34105	Voltamax 12 VDC (500mA) Power Supply
STI-34105/UK	Voltamax 12 VDC (500mA) Power Supply
STI-34105/EURO	Voltamax 12 VDC (500mA) Power Supply
STI-30105	Extended Antenna



### **Safety Technology International (Europe) Ltd.**

Unit 49G Pipers Road • Park Farm Industrial Estate • Redditch  
Worcestershire • B98 0HU • England • Tel: 44 (0) 1527 520 999  
Fax: 44 (0) 1527 501 999 • Freephone: 0800 085 1678 (UK only)  
E-mail: [info@sti-europe.com](mailto:info@sti-europe.com) • Web: [www.sti-europe.com](http://www.sti-europe.com)

### **Safety Technology International, Inc.**

2306 Airport Rd • Waterford, MI 48327  
Phone: 248-673-9898 • Fax: 248-673-1246  
[info@sti-usa.com](mailto:info@sti-usa.com) • [www.sti-usa.com](http://www.sti-usa.com)