

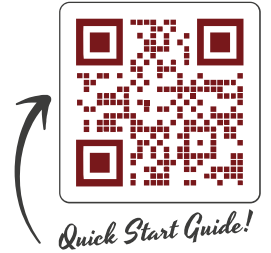

LIGHTING • FIRE & CO DETECTION



COMBO RADIO FREQUENCY FAST FIX MAINS SMOKE & HEAT DETECTOR

WITH 10 YEAR RECHARGEABLE LITHIUM BATTERY

**FAST
FIX REPRO**



FEATURES

- Contains both a smoke chamber & a heat sensor
- Wirelessly interconnect with up to 20 detectors
- 10yr Rechargeable Lithium Battery Backup
- Loud 85dB alarm
- Fast Fix base included
- Insect proof
- Test function and hush feature
- Tamper proof
- Compatible with Hispec Control Unit HSSA/CU/RF10-PRO

TECHNICAL INFORMATION

Scheme Rating:	D1
Detection Type:	Smoke & Heat Sensitive
Power Source:	220-240v
Battery Backup:	Rechargeable Lithium Battery with 10 year life
Alarm Sound Level:	85dB at 3 metres
Temp Rating:	60°C Fixed Temp (Heat activities)
Operating Temp:	0°C - 40°C
Operating Current:	<40mA operation
Radio Frequency Range:	Up to 80m in open areas & 30m indoors
Ambient Humidity:	10% - 90%
Weight:	158g
Approvals:	BS EN14604:2005/ AC:2008 BS 5446-2:2003

Product Code: HSSA/PH/RF10-PRO

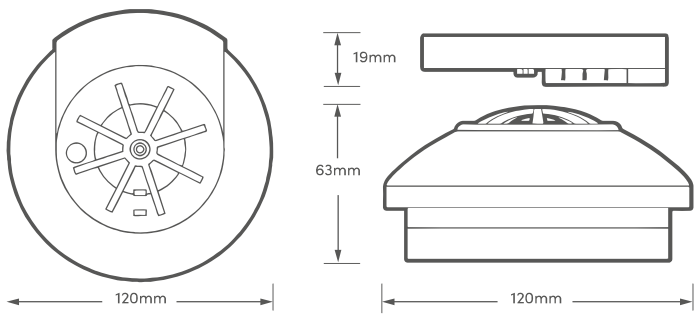

hispec.co.uk

