

Sounder Control Unit with Isolator



Technical Data

All data is supplied subject to change without notice. Specifications are typical at 24V, 25°C and 50% RH unless otherwise stated.

Supply voltage (Vmin–Vmax)	17-28V DC
Digital communications protocol	XP95, Discovery & CoreProtocol compatible 5-9V Peak to Peak
Current consumption (max) at 24V DC	
Power up surge (100ms max)	2.6mA
Quiescent (10kΩ End-of-Line fitted)	1.95mA
Sounders operated	1.7mA
Fault yellow LED on	3.6mA
Sounder line short-circuit	2.8mA
Maximum continuous current	1A
Local power supply current consumption	
Relay off	1mA at 9V 3mA at 32V
Sounders and red LED on	44mA at 9V (+ sounder load) 47mA at 32V (+ sounder load)
Sounder output monitoring voltage	9–11V DC
Maximum sounder circuit voltage	32V DC
Maximum sounder circuit current	1A at 30V DC (inductive or resistive)
On resistance	0.2Ω
Maximum continuous current	1A
Maximum switching current	3A
Operating temperature	-20°C to 70°C
Humidity	0% to 95%RH (no condensation or icing)
Vibration, impact and shock	EN 54-17 & EN 54-18
IP Rating	Designed to IP54
Approvals & standards	EN 54-17, EN 54-18, CPD, LPCB, VdS, CCCF, CCMG, CCS & VNIPO
Dimensions	48mm height x 150mm width x 90mm depth
Weight	240g

Product Overview

Product Type	Sounder Control Unit with Isolator
Part No.	55000-852
Digital Communication Protocol	XP95®, Discovery® & CoreProtocol® compatible

Product Information

The Sounder Control Unit with Isolator is used to control the operation of a zone of externally powered sounders, visual indicators and VADs and to report their status to Apollo compatible control equipment.

The Sounder Control Unit with Isolator allows the devices to be operated continuously or be pulsed, 1 second on, 1 second off. Devices may be operated individually or in groups and, whichever address mode has been applied, may be synchronised when in pulsed operation.

An opto-coupled input is provided to monitor the state of the external power supply.

The Sounder Control Unit with Isolator is fitted with a bi-directional short-circuit isolator and will be unaffected by loop short-circuits on either loop input or output. For further information on isolators please refer to datasheet PP2090, available on request.

Electrical Consideration

The unit is loop powered and operates at 17–28V DC. It requires a local power supply of 9–32V DC to power the external load, which may be up to 1A.

With reference to Figure 1, a polarising diode is required with each alarm device, as sounders are operated by voltage reversal, provided by a double-pole change-over relay. The sounder circuit is protected by a miniature (TR5) fuse rated at 1A.

Sounder Control Unit with Isolator

Figure 1 Sounder Control Unit with Isolator Wiring Diagram

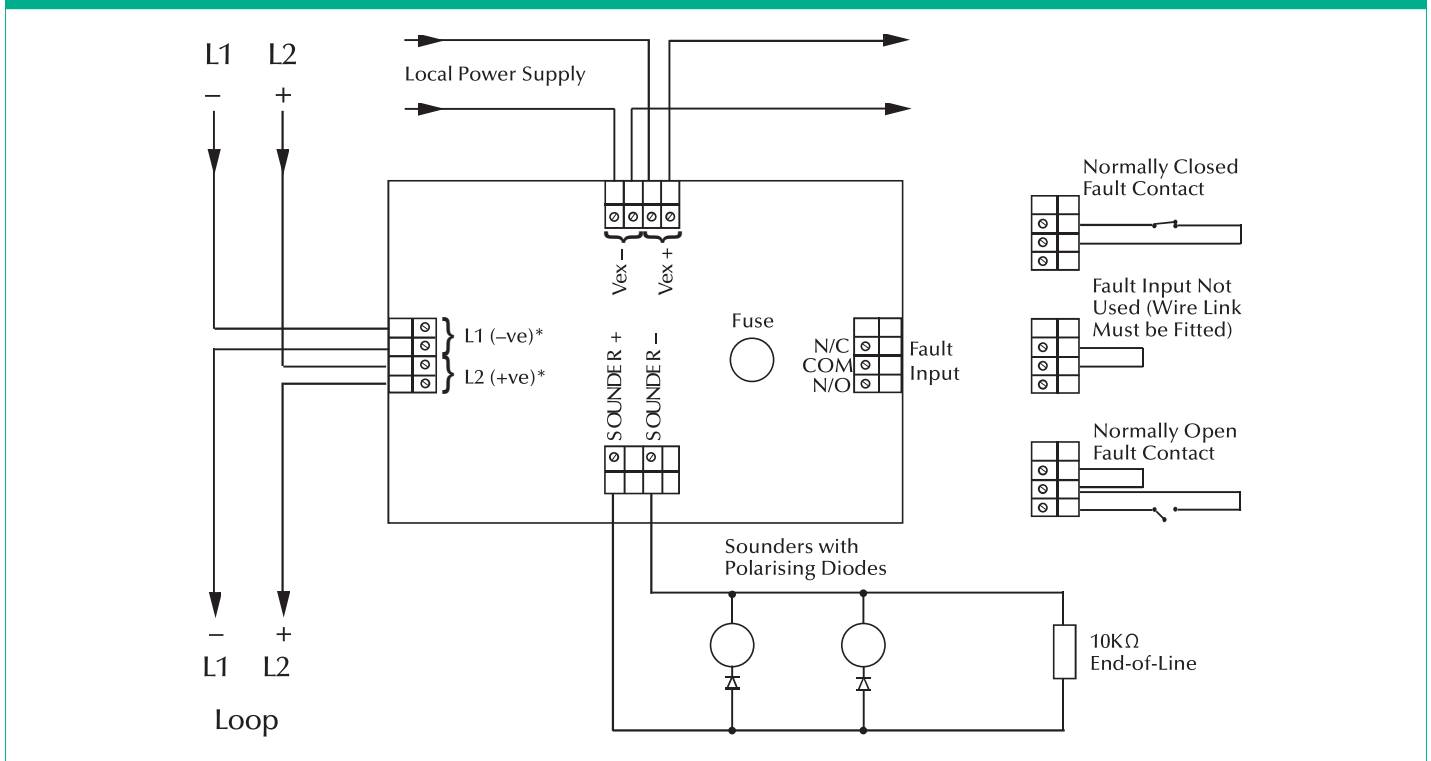

Table 1 Digital communications protocol compatibility

Protocol	Device behaviour
XP95/Discovery	XP95
CoreProtocol (fire control panel dependant)	XP95

It may be desirable, in alarm conditions, to switch more than one Sounder Control Unit with Isolator simultaneously. To enable this, units may be drawn together to form a group and given a group address which is common to all units in the group. When a device recognises its group address, it will process the forward command bits but it will not return any data to the control panel on that address. If it is required to confirm the status of the output bits of devices under group address control, it is necessary to poll all devices in the group by their individual addresses.

Mechanical Construction

The Sounder Control Unit with Isolator (see Figure 2) is normally supplied with a backbox for surface mounting and is intended for indoor use only. The backbox is moulded from the same white self-extinguishing polycarbonate as Apollo detectors.

Three LEDs, one red and two yellow are visible through the front cover of the enclosure. The red one pulses or is illuminated continuously to indicate that the sounders are, respectively pulsed or switched on continuously.

One yellow LED is illuminated whenever a fault has been detected.

The other yellow LED is illuminated whenever the built-in isolator has sensed a short-circuit loop fault.

Addressing

The Sounder Control Unit with Isolator responds to its own individual address set with a 7-segment DIL switch. It also responds both to a group address, set by means of a 4-segment DIL switch, and to a pulsed-mode synchronisation address which is embedded in the unit.

Fault Monitoring

In addition to the monitoring of open and short-circuit faults on the sounder wiring, the Sounder Control Unit has a facility to monitor the presence and polarity of the external power supply. This is achieved by a fault monitoring circuit which also includes an input to monitor a volt-free contact (such as a fault relay in the external power supply).

EMC Directive 2004/108/EC

The Sounder Control Unit with Isolator complies with the essential requirements of the EMC Directive 2004/108/EC, provided that it is used as described in this data sheet.

A copy of the Declaration of Conformity is available from Apollo on request.

Construction Products Directive 89/106/EEC

The Sounder Control Unit with Isolator complies with the essential requirements of the Construction Products Directive 89/106/EEC.

A copy of the Declaration of Performance is available from Apollo on request.

Sounder Control Unit with Isolator

Figure 2 Sounder Control Unit with Isolator

