

Dorgard SmartSound Troubleshooting Guide

Index

- Carpet and Floor Protection.....1
- Filter Out Short Alarms.....2
- Delay Door Closure.....3
- Door Close Time Operation.....4
- Factory Reset.....5

Technical Diagram

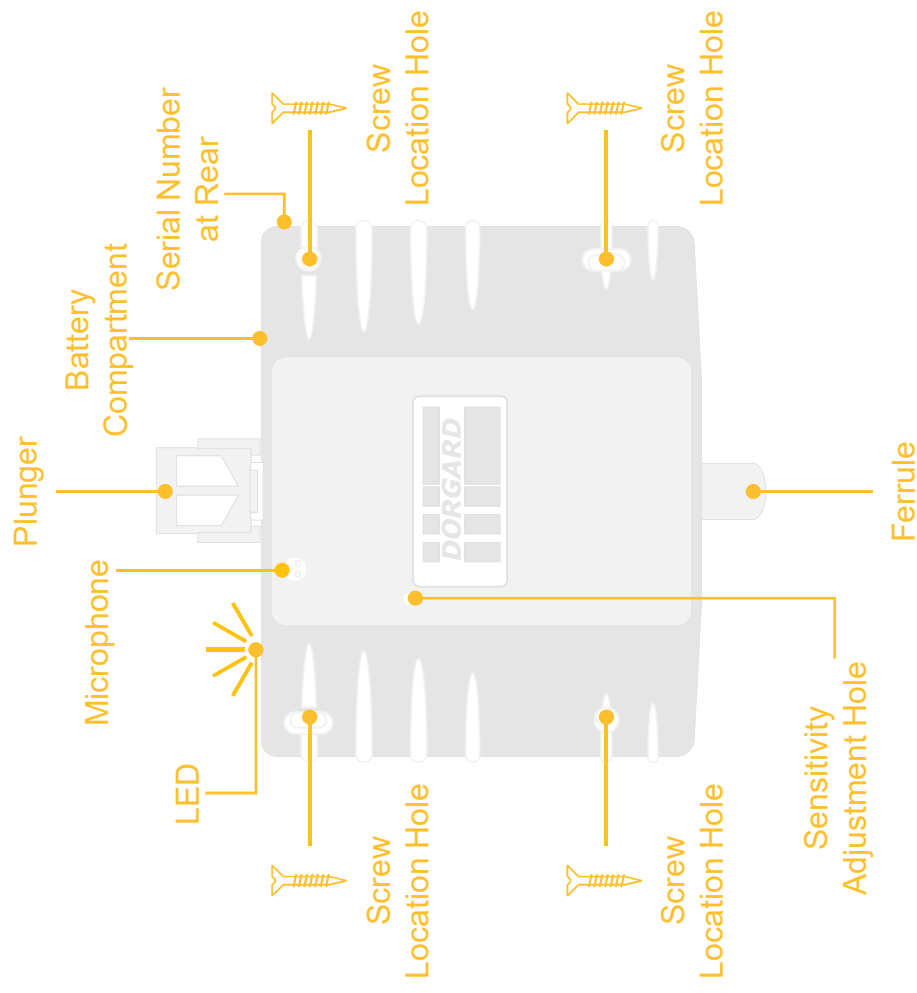

Carpet and Floor Protection

1



Using your smartphone, go to fireco.online/carpet or scan the QR code to download the sound file.

2

Remove the battery.

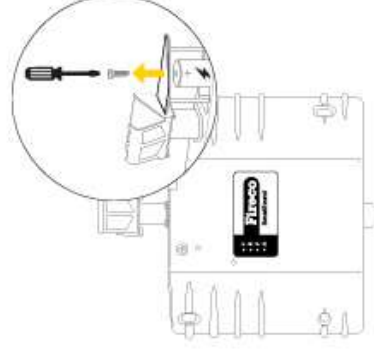

3

Press play on the sound file with the phone next to the unit.



4

Whilst the sound file is playing re-insert the batteries. All lights will show green to confirm the application.



Filter Out Short Alarms

1

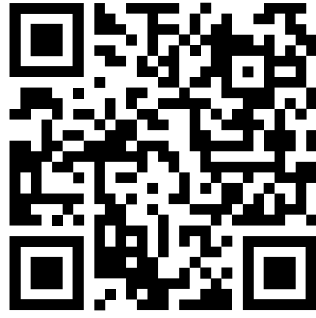

Using your smartphone, go to fireco.online/filter-12 or scan the QR code to download the sound file.

2

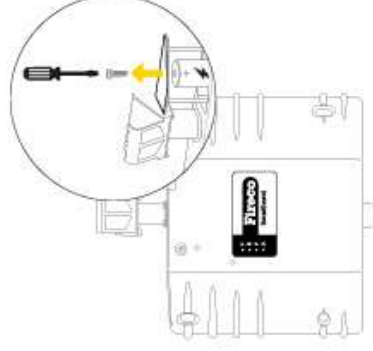

Remove the battery.

3



Press play on the sound file with the phone next to the unit. Whilst the sound file is playing re-insert the batteries.

4



All lights will show green to confirm the application.

Delay Door Closure

1

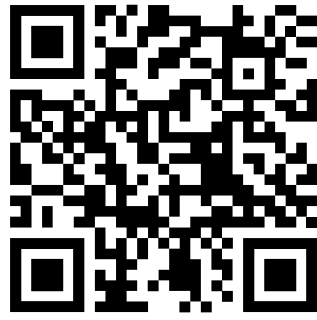

Using your smartphone, go to fireco.online/delay-60 or scan the QR code to download the sound file.

2

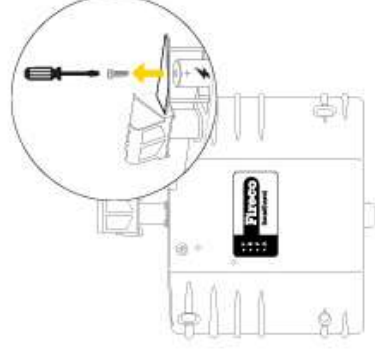

Remove the battery.

3



Press play on the sound file with the phone next to the unit. Whilst the sound file is playing re-insert the batteries.

4



All lights will show green to confirm the application.

Fireco

Door Close Time

1

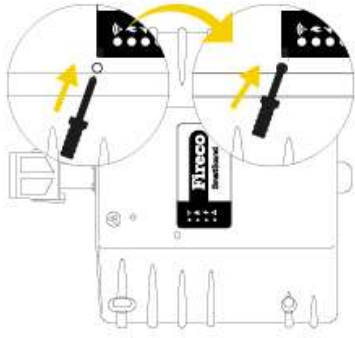

Insert the mini screwdriver provided into the hole on the front of the unit and press the button.

2

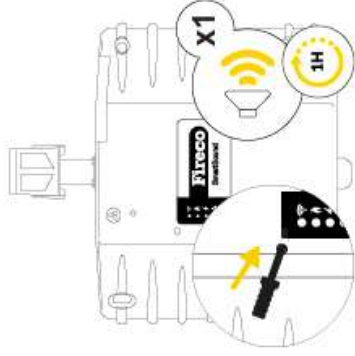

The unit will beep once for every hour from the current time. If the time is 4pm and you want the unit to close the door at 8pm, you need to let the unit beep 4 times before pressing the button again.

3

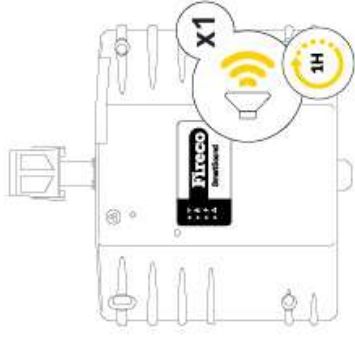

The unit will beep back the number of hours you have set to confirm. To change the time you have set, remove and re-insert the batteries and follow steps 1-3. Note: If you are applying the other features, set up Door Close Time last.

Factory Reset

1

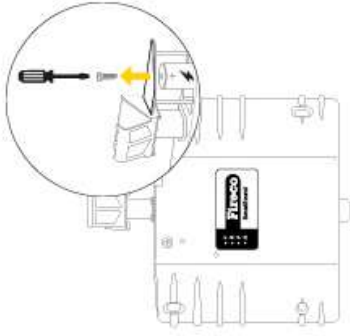

Remove the batteries.

2

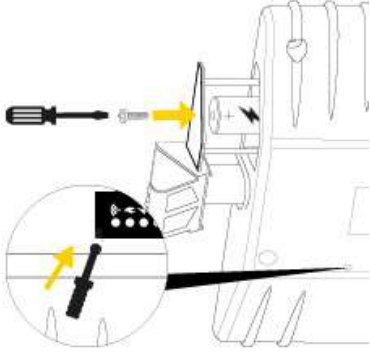

Hold down the button on the front of the unit using the mini screwdriver provided and reinsert the batteries - **this must be done simultaneously.**

3

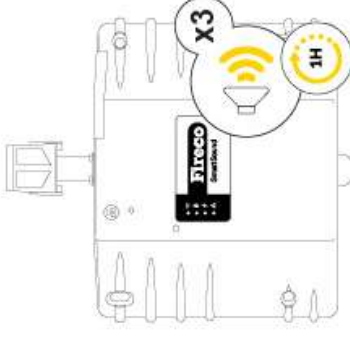

The unit will beep 3 times to confirm the reset.

