

INSTALLATION INSTRUCTIONS

322 LEVER OUTSIDE ACCESS DEVICE

NOTES ON INSTALLATION

THIS OUTSIDE ACCESS DEVICE (OAD) PROVIDES A LEVER OPERATED LOCKING ENTRY WITH MASTER KEYING FACILITY.

THIS UNIT IS SUITABLE FOR USE ON DOORS TOGETHER WITH EXIDOR 200/300 SERIES PANIC & EMERGENCY EXIT HARDWARE.

THE DEVICE ALWAYS ALLOWS IMMEDIATE EXIT VIA THE PANIC / EMERGENCY EXIT HARDWARE REGARDLESS OF WHETHER THIS OUTSIDE ACCESS DEVICE IS LOCKED OR UNLOCKED.

THIS DEVICE CAN BE FITTED AS PART OF THE INITIAL INSTALLATION OF THE PANIC / EMERGENCY EXIT HARDWARE OR RETROFITTED TO AN EXISTING INSTALLATION.

FOR DOUBLE DOOR INSTALLATIONS WITH REBATED MEETING STILES USED IN COMBINATION WITH DOUBLE DOOR PANIC / EMERGENCY EXIT SYSTEMS THE OUTSIDE ACCESS DEVICE MUST BE FITTED ON THE FIRST OPENING (LAST CLOSING) DOOR.

BEFORE INSTALLATION CHECK THAT BOTH THE FRAME AND DOOR ARE IN GOOD CONDITION, NOT TWISTED AND FREE FROM BINDING. ENSURE THE DOOR IS HUNG ON THREE SUITABLE HINGES AND THAT IT OPENS SMOOTHLY AND CLOSES SQUARE TO THE FRAME.

THIS EQUIPMENT MUST BE FITTED BY A COMPETENT INSTALLER.

THESE INSTALLATION INSTRUCTIONS MUST BE SUPPLIED TO THE USER BY THE INSTALLER WHEN THE INSTALLATION IS COMPLETE.

IF THESE INSTALLATION INSTRUCTIONS ARE DISREGARDED NO RESPONSIBILITY CAN BE ACCEPTED BY THE MANUFACTURER.

NOTES ON OPERATION

ROTATE THE KEY ANTI-CLOCKWISE TO UNLOCK THE DEVICE. ROTATE THE KEY CLOCKWISE TO LOCK THE DEVICE.

IN BOTH CASES ROTATE THE KEY UNTIL IT STOPS ('MECHANISM CLICKS') THEN COUNTER-ROTATE TO RETURN TO THE NEUTRAL POSITION TO REMOVE THE KEY, **DO NOT TRY TO CONTINUE ROTATING THE KEY.**

WHEN LOCKED THE OPERATION OF THE LEVER IS BLOCKED.

WHEN UNLOCKED THE LEVER WILL MOVE FREELY AND OPERATE THE PANIC / EMERGENCY EXIT DEVICE INSTALLED ON THE INSIDE OF THE DOOR.

TO PROTECT THE DEVICE AGAINST EXCESSIVE FORCE A SHEAR SCREW IS USED TO SECURE THE LEVER. THIS UNIT IS SUPPLIED WITH ONE SHEAR SCREW.

REPLACEMENT SHEAR SCREWS & LEVER HANDLES ARE AVAILABLE.

PLEASE REFER TO THE 'REPLACING THE SHEAR SCREW' SECTION ON THE BACK PAGE.

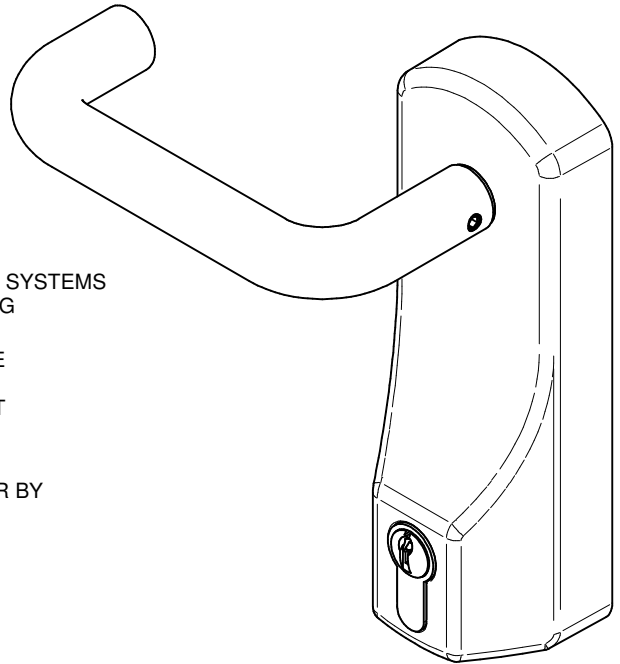

DEVICE PREPARATION

A LEVER HANDING

ATTACH THE LEVER TO THE SHANK IN THE CORRECT ORIENTATION TO SUIT THE DOOR HANDING. (SEE DIAGRAMS BELOW) SECURE TO THE DEVICE WITH THE SUPPLIED SHEAR SCREW. USE THE HEX KEY PROVIDED. DO NOT OVER TIGHTEN.

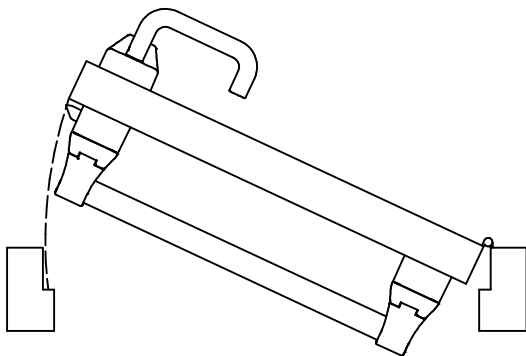

LH DOOR

(HINGED ON RIGHT, OPENING OUTWARDS)

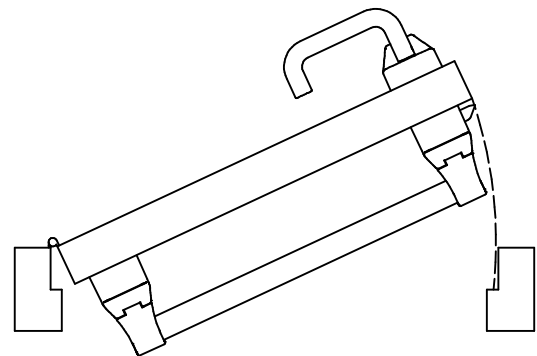
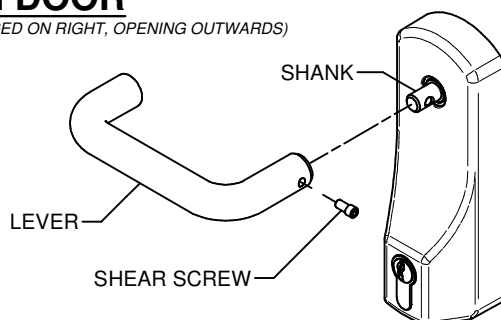

RH DOOR

(HINGED ON LEFT, OPENING OUTWARDS)

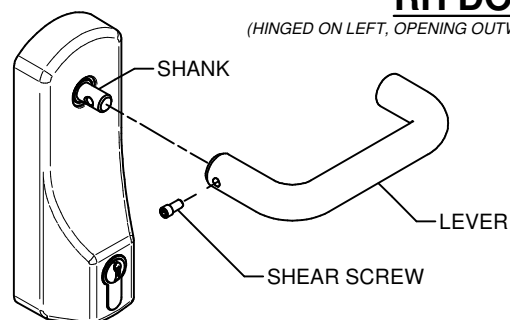

DEVICE PREPARATION

B SETTING THE DRIVE SPINDLE HANDING

THE **DRIVE SPINDLE** MUST BE SET TO SUIT THE REQUIRED HANDING / TYPE OF EXIT DEVICE. REFER TO THE DIAGRAMS TO DETERMINE THE REQUIRED POSITION. FOLLOW THE PROCEDURE BELOW TO SET THE HANDING.

1. ENSURE DEVICE IS UNLOCKED. FULLY OPERATE THE **LEVER** & HOLD IN POSITION. THE **DRIVE SPINDLE** WILL ROTATE.
2. USING ONE OF THE SQUARE SPINDLES (IN SCREW PACK).
3. CONTINUE TO TURN THE **DRIVE SPINDLE** (IN DIRECTION OF ROTATION) TOWARDS THE REQUIRED POSITION UNTIL IT STOPS.
4. RETURN THE **LEVER** TO THE START POSITION.
5. CONTINUE TO ROTATE THE **DRIVE SPINDLE** UNTIL THE MARK ON THE **DRIVE SPINDLE** LINES UP WITH THE APPROPRIATE MARK IN THE BACKPLATE. THE **DRIVE SPINDLE** IS NOW HANDED.

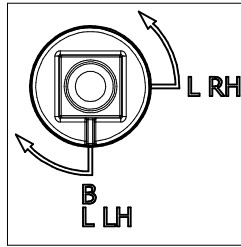
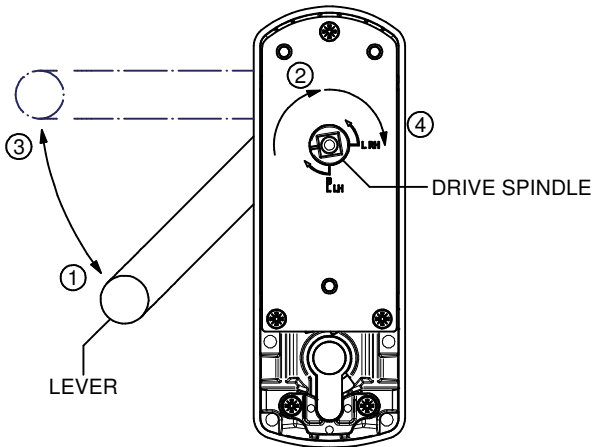

B / L LH POSITION

TO SUIT:
 ALL SHOOT BOLT VERSIONS
 (E.G. : 293, 294, 307, 308, 310, 311)
 REGARDLESS OF DOOR HANDING
 LATCH UNITS (EG. 296 & 297)
 USED ON LEFT HAND DOORS

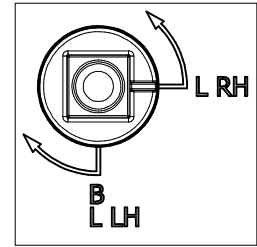

L RH POSITION

TO SUIT:
 LATCH UNITS (EG. 296 & 297)
 USED ON RIGHT HAND DOORS

C INSTALLATION / REPLACEMENT OF CYLINDER

1. REMOVE THE 2 **CYLINDER BRACKET SCREWS**. WITHDRAW THE **CYLINDER BRACKET** FROM THE UNIT.
2. CHANGE / INSTALL THE **CYLINDER**. SECURE CYLINDER TO BRACKET WITH THE M5 x 20 **CYLINDER SCREW** PROVIDED.
3. REPLACE THE BRACKET / CYLINDER ASSEMBLY. RE-SECURE WITH THE **CYLINDER BRACKET SCREWS**.

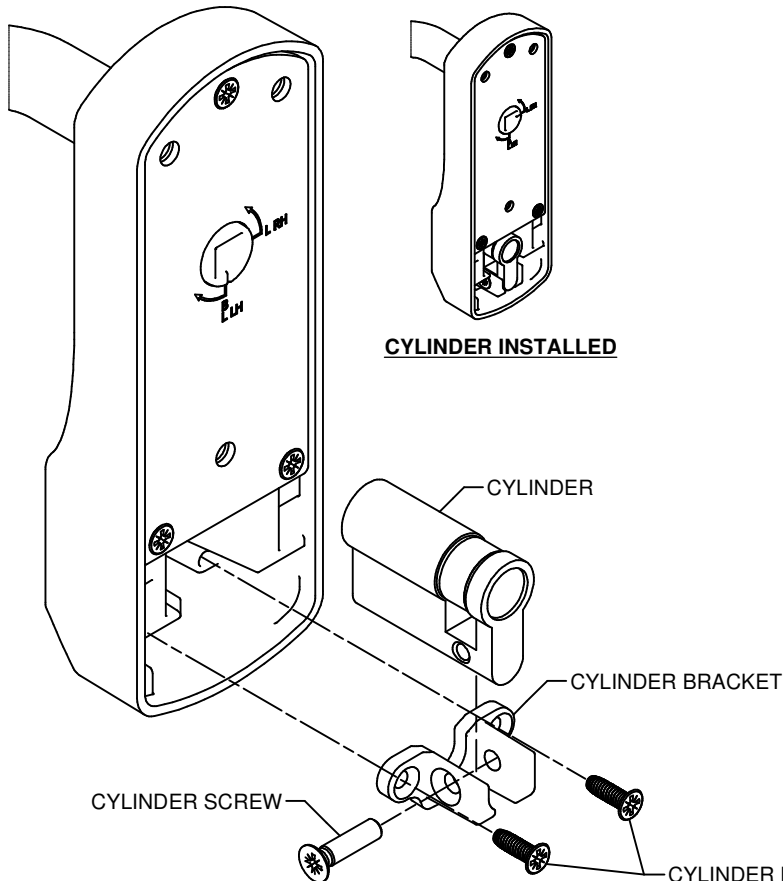

COMPATIBLE CYLINDER DIMENSIONS DIN 18252 EURO PROFILE CYLINDER

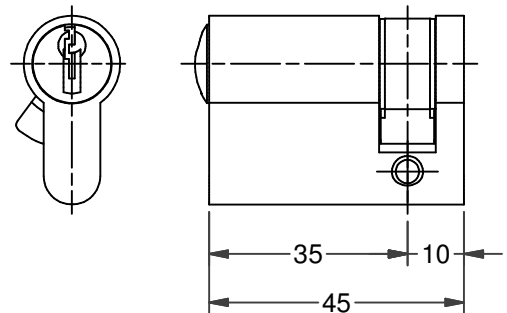

DEVICE INSTALLATION

1 ESTABLISH UNIT POSITION

WORKING ON THE INSIDE FACE OF THE DOOR.
 USE THE TEMPLATE TO ESTABLISH THE FIXING POSITION OF THE PANIC / EMERGENCY EXIT DEVICE.
 FOLLOW THE INSTRUCTIONS ON THE TEMPLATE
 DETERMINE HEIGHT 900mm TO 1100mm FROM FLOOR
 ALIGN TEMPLATE CORRECTLY WITH:
 THE EDGE OF FRAME (FOR SINGLE DOOR) OR THE
 EDGE OF 2nd OPENING DOOR (FOR DOUBLE DOORS)
 FOR EXISTING INSTALLATIONS WHERE ACCESS DEVICE
 IS TO BE RETROFITTED. REMOVE EXIT DEVICE & ALIGN
 TEMPLATE WITH THE EXISTING EXIT DEVICE FIXING HOLES.

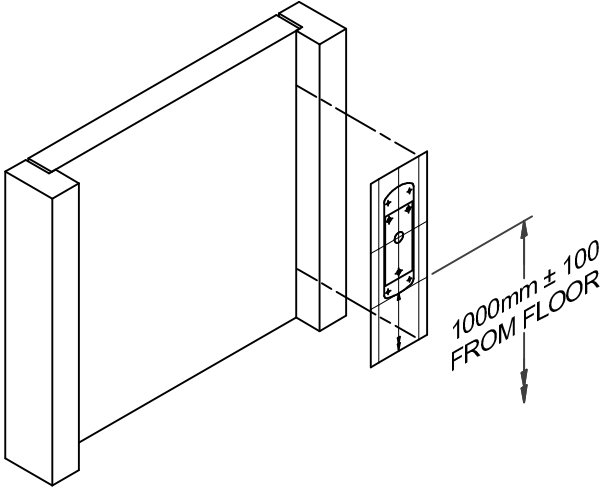

2 PREPARE DOOR

PILOT THE EXIT DEVICE FIXING HOLES.
 DRILL Ø16mm SPINDLE HOLE THROUGH THE DOOR.
FOR TIMBER DOORS:
 DRILL THROUGH 3 OFF CLEARANCE HOLES FOR
 ACCESS DEVICE FIXINGS. FOR IMPROVED STRENGTH
 THE MORTICE MOUNTING PLATE CAN BE USED.
 THE PLATE MUST BE MORTISED FLUSH INTO DOOR FACE.
FOR STEEL DOORS:
 DRILL THROUGH 3 OFF CLEARANCE HOLES FOR
 ACCESS DEVICE FIXINGS. COUNTERSINK THESE
 HOLES DIRECTLY ON THE INSIDE FACE OF THE DOOR.

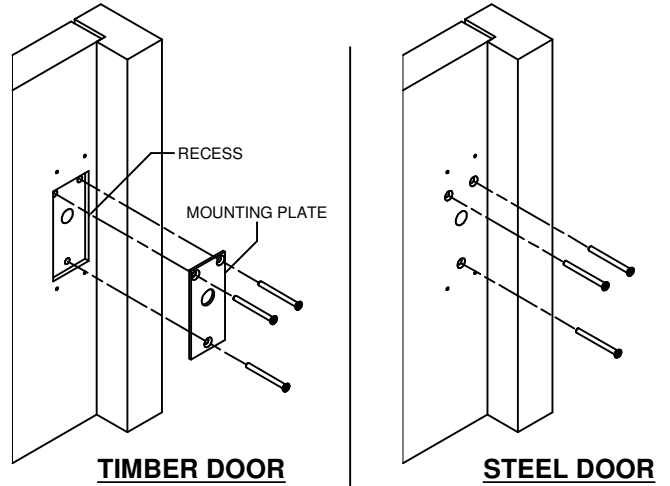

3 PREPARE FIXING SCREWS

TRIAL FIT THE 3 OFF M5 x 70 FIXING SCREWS.
 CUT THE SCREWS TO PROVIDE A MAXIMUM
 PROJECTION OF 15mm FROM THE OUTSIDE
 FACE OF THE DOOR.

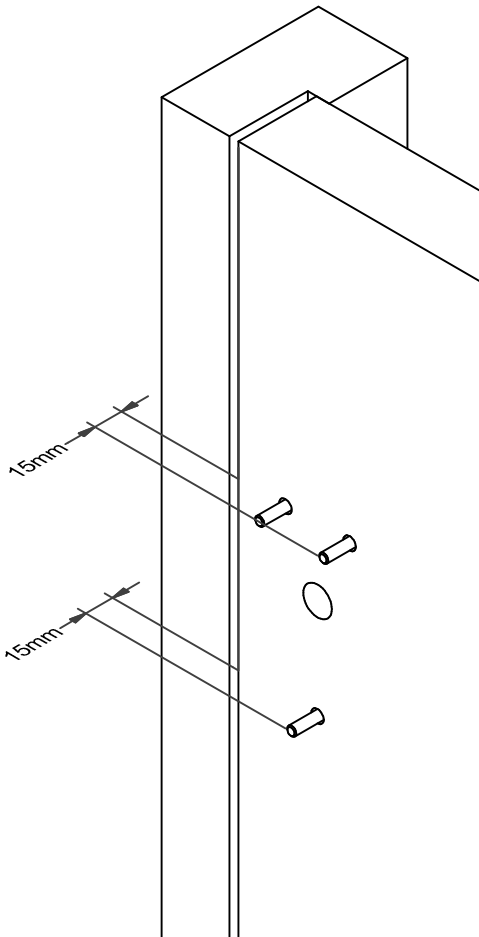

OUTSIDE DOOR FACE SHOWN

4 SELECT & PREPARE SPINDLE

SELECT THE CORRECT TYPE OF SPINDLE TO SUIT THE
 PANIC / EMERGENCY EXIT DEVICE BEING USED.
 FOR LATCH TYPE FIT THE SPINDLE ADAPTOR (SEE DIAGRAMS)
 ENSURE IT IS FULLY INSERTED INTO THE SQUARE DRIVE OF THE
 PANIC / EMERGENCY EXIT LATCH UNIT.
 FIT THE ACCESS DEVICE USING THE PREVIOUSLY PREPARED SCREWS.
 INSERT THE CORRECT DRIVE SPINDLE THROUGH THE DOOR AND
 LOCATE INTO THE SQUARE DRIVE / ADAPTOR IN THE ACCESS DEVICE.
 MARK 13mm PROJECTION FROM THE INSIDE DOOR FACE.
 (NOTE: WHEN USING THE MORTICE MOUNTING PLATE MEASURE FROM
 THE FACE OF THE DOOR NOT THE PLATE.)
 CUT THE SPINDLE TO LENGTH. DE-BURR THE CUT END.
 (NOTE: CUT THE SQUARE END WHEN USING THE LATCH SPINDLE.)

PLAIN SQUARE (BOLT) SPINDLE
 USE FOR SHOOT BOLT VERSIONS
 (E.G. 293, 294, 307, 308, 310, 311)

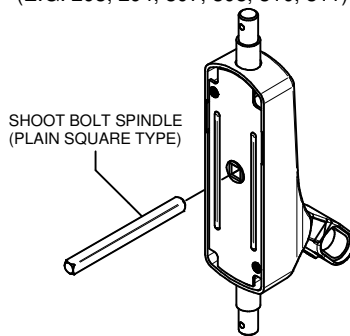

REDUCED END (LATCH) SPINDLE
 USE FOR LATCH VERSIONS ONLY
 (E.G. 296 & 297)

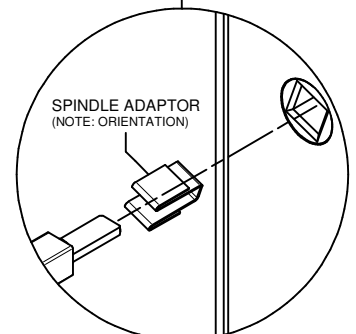
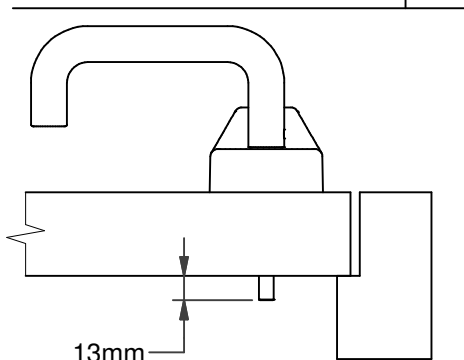
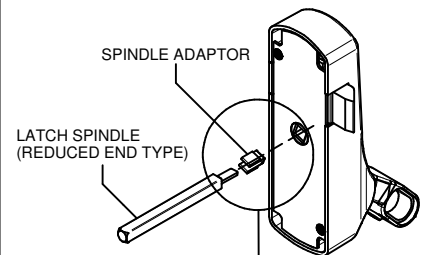

DEVICE INSTALLATION

5 INSTALL THE EXIT DEVICE

CONTINUE TO INSTALL THE EXIT DEVICE FOLLOW THE INSTRUCTIONS SUPPLIED WITH THAT DEVICE.

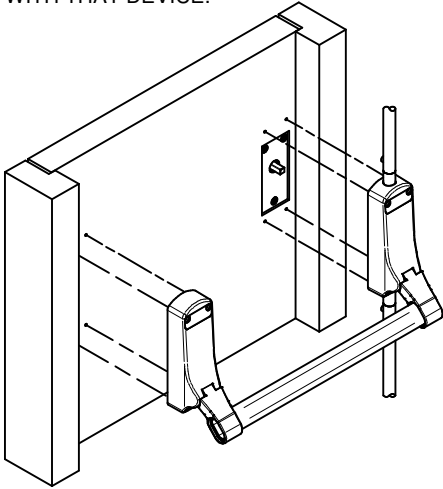

6 CHECK / TEST INSTALLATION

TEST THE OPERATION OF THE FINISHED INSTALLATION. CHECK FOR FREE AND CORRECT OPERATION OF BOTH THE OUTSIDE ACCESS DEVICE AND THE PANIC / EMERGENCY EXIT HARDWARE.

REPLACING THE SHEAR SCREW

TO REPLACE A BROKEN SHEAR SCREW:

- CAREFULLY UNSCREW THE BROKEN SHEAR PIN HEAD.
NOTE: USE SQUARE ENDED (NONE BALL END) 3mm HEX KEY
- PULL THE LEVER OFF TO REMOVE. (AVOID ROTATING)
- CLEAR THE REMAINING SHEAR SCREW FROM THE SHANK
NOTE: PUSH OUT FROM THE NONE SHEARED SIDE.
- INSPECT THE SHANK & LEVER FOR DAMAGE.
REMOVE ANY BURRS TO ALLOW THE LEVER TO RE-FIT.
NOTE: REPLACEMENT LEVERS ARE AVAILABLE.
- RE-FIT LEVER WITH A NEW SHEAR SCREW.

MAINTENANCE

WEEKLY:

CHECK THE CORRECT OPERATION OF THE OUTSIDE ACCESS DEVICE IN CONJUNCTION WITH THE PANIC / EMERGENCY EXIT DEVICE.

3 MONTHLY:

CHECK THAT ALL THE FIXINGS ARE SECURE.

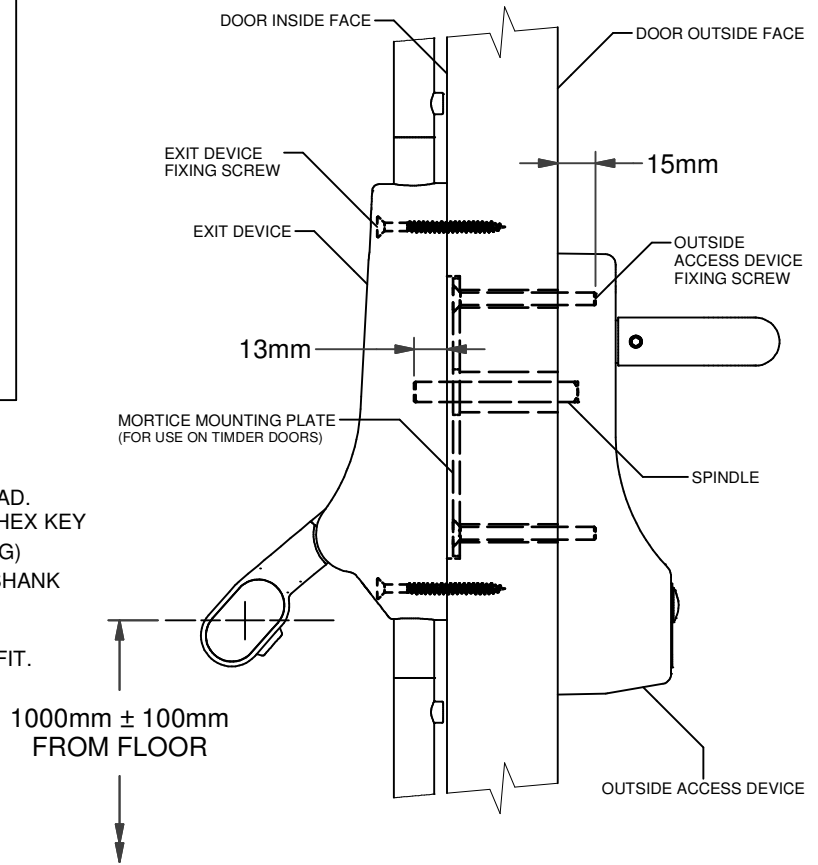

BOX CONTENTS & SPARES

ITEM	ITEM REF.	QUANTITY
DEVICE MAIN ASSEMBLY	-	1
LEVER	P3113	1
MORTICE MOUNTING PLATE	P3057	1
SCREW PACK (CONTAINING):		
SHOOT BOLT SPINDLE (PLAIN SQUARE)	-	1
LATCH SPINDLE (REDUCED END)	-	1
LATCH SPINDLE ADAPTOR	P1730	1
LONG M5 MACHINE SCREW (UNIT FIXINGS)	-	3
SHORT M5 MACHINE SCREW (CYLINDER FIXING)	-	1
3mm HEX KEY (FOR SHEAR SCREW)	-	1
SHEAR SCREW	P3118	1
KEYS (IF SUPPLIED WITH LOCK)	-	3
TEMPLATE	-	1
INSTALLATION INSTRUCTIONS	-	1

FRED DUNCOMBE LTD.
 PROGRESS DRIVE, CANNOCK, STAFFORSHIRE, WS11 0JE
 Tel. +44 (0) 1578661 Fax. +44 (0) 570050
 web. www.fredduncombe.co.uk