

# DECORATIVE TWIN SPOT

www.ringtail.co.uk - +44 (0) 1772 336335 - sales@ringtail.co.uk

Ringtail  
Lighting



The TSC Curved Twin spot provides a decorative solution to emergency lighting in large interior open areas.

- Housed in a silver finished steel enclosure.
- Fitted with twin high output halogen lamps.
- IP20 ingress protection
- Passes 850° C hot-wire test.
- Designed in accordance with requirements of EN60598-2-22.
- Suitable for incorporation into an emergency lighting system complying with BS5266-1:2011.
- The TSC range comes complete with lamps and batteries. Non-Maintained as standard.

## Specification

- Decorative
- Adjustable Heads
- Tungsten Halogen
- 3 Hour Standby Operation
- LED Lamp Monitoring



## Options

### Options

/RH Remote Heads

## Dimensions

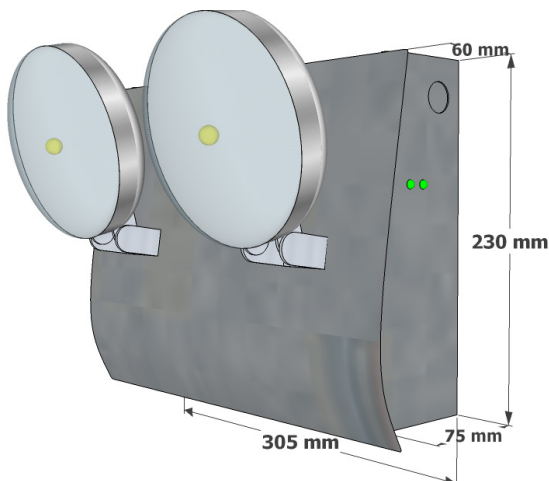

## Suitable Applications

- Suitable for incorporation into an emergency lighting system complying with BS5266-1:2011.

## Technical Specification

	Model	Lamp Type	Power Con	Battery	Duration	Weight	Output
<b>TSC20NM</b>	Non Maintained	2 x 20W Tungsten Halogen	24 W	12V 14Ah	3 Hours	7.35 Kg	2 x 360

## Installation Notes

- Three 20mm knockouts are available on the back and sides of the unit offering flexibility of cabling.

## Materials / Finish

- Housed in a silver finished steel enclosure.
- Fitted with twin high output flood lights utilising halogen lamps.

## Catalogue Numbers

**TSC20NM**

Non Maintained