

A weatherproof IP65 ceiling mounted exit sign. The ESP provides you with a single or double sided exit sign made from white polycarbonate suitable for many external applications. It is also suitable for areas that require thorough cleaning such as hospital corridors. The ESP Light has cable knockouts, which are provided in the sides and a BESA entry in the base. Complying with the requirements of EN60598-2-22 and suitable for incorporation into an emergency lighting system complying with BS5266-1:2005. With the optional recessing kit this exit sign is a versatile all rounder.

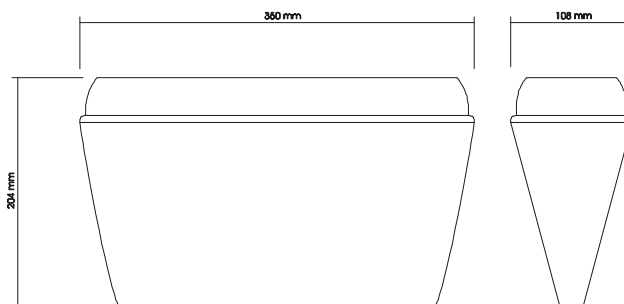

- IP65 External Use
- Escape Route Sign
- Choice of Legend
- Ceiling Mounted
- Central Battery Versions
- Self-Contained
- Centrally Supplied



	Mode	Lamp Type	Battery	Duration	Weight	Dimensions
ESP8M	Maintained	8W	2.4V 4Ah	3 Hours	1.45 Kg	L 350mm x
ESP8NM	Non Maintained	8W	2.4V 4Ah	3 Hours	1.2 Kg	W 108mm x
ESP8/SL/*	Slave	8W			850 g	D 204mm

* Please suffix voltage required i.e. 24, 50, 110, 230

Suffix part number with

/L	-	Left Arrow
/R	-	Right Arrow
/REC	-	Recessing Kit
/ST	-	Self Test

NOTE: All exit signs arrow down as standard if other direction is required please specify