

DISCREET LED EMERGENCY LIGHTING

www.ringtail.co.uk - +44 (0) 1772 336335 - sales@ringtail.co.uk

Ringtail
Lighting



This unit is the ultimate in concealed emergency lighting. A single LED and remote battery pack make an attractive alternative.

- LED down lighter using one, high-illumination white LED in a 50mm diameter white polycarbonate housing.
- Exceptionally economical unit - Low energy requirement, long life-span LEDs and batteries.
- Complying with the requirements of EN60598-2-22.
- Suitable for incorporation into an emergency lighting system complying with BS5266-1:2011.
- IP30 Rated.
- Available in round or square formats.
- Also available is an intumescent hood to restore the fire rating of the ceiling if required.

Specification

- Non Maintained
- 40mm Cut out
- Recess mounted
- 50mm diameter viewable
- White High Output LED
- Status Indicator LED



Options

Options

/SURF Surface mount enclosure

/DALI DALI

Note: All exit signs are arrow down as standard please specify other direction if required

Dimensions

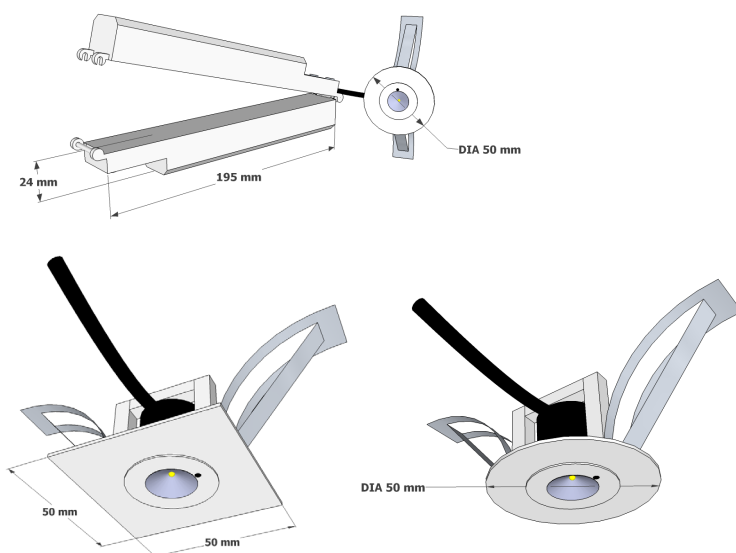

Suitable Applications

- Suitable for use on escape routes.
- Suitable for incorporation into an emergency lighting system complying with BS5266-1:2011.

Technical Specification

	Model	Lamp Type	Power Con	Battery	Duration	Weight
TWR3NM & TWS3NM	Non Maintained	3W LED	5.6VA	2.4V 4Ah	3 Hours	1.98 Kg
TWR3NM/ST & TWS3NM/ST	Non Maintained	3W LED	7.65VA	2.4V 4Ah	3 Hours	2.15 Kg

Installation Notes

- Recess mounting option -40mm diameter cut out.
- Surface mount option available.





Surface Mounted option

Materials / Finish

- LED driver and battery pack are enclosed in a white articulated plastic housing.

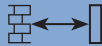
Mounting Height

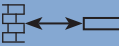
Mounting Height (M)					
2.5	3.40	5.90	5.90	3.40	OPEN AREAS 0.5 LUX MIN (ANTI-PANIC)
4.0	3.60	8.89	8.89	3.60	
2.5	2.50	5.90	5.90	2.50	ESCAPE ROUTE 1.0 LUX MIN (NORMAL RISK)
4.0	2.30	7.30	7.30	2.30	

Catalogue Numbers

TWR3NM & TWS3NM	Non Maintained	3W LED
TWR3NM/ST & TWS3NM/ST	Non Maintained	3W LED