

FIRERAY

2000

Optical Beam Smoke Detector



Fire Fighting Enterprises Ltd.

Approved by VdS No. : G 297058
to EN54 Part 12

FEATURES

- Range 10 – 100 Metres
- 11.5Vdc to 28Vdc operating voltage
- Selectable alarm thresholds
- Low current consumption
- Ground level electronics
- Manual or automatic reset
- Automatic contamination compensation



System Description

The Fireray 2000 is a linear beam smoke detection system capable of protecting an open indoor area of up to 1500 square metres.

The System comprises a Transmitter which projects a modulated infrared beam over an area to a Receiver, which then forwards a signal to a Control Unit for analysis. The System can detect smoke particles obscuring the beam path. When obscured for a predefined length of time the Control Unit will generate an alarm.

Smoke Detection

When smoke is present in the beam path the signal received by the Receiver is reduced relative to the density of the smoke. If the density of the smoke reduces the signal below a preset threshold for a period of 10 seconds an alarm relay is activated.

There are 3 selectable threshold levels available, 25%, 35%, and 50%. (25% being the most sensitive).

Auto Reset

The alarm relay is configurable and can be either latching or non-latching.

If non-latching is selected the alarm relay will reset 5 seconds after the smoke has cleared.

If latching is selected the alarm relay will remain set until either a power down reset is performed, or the Controller Unit receives an external reset.

Automatic Gain Control

The Control Unit supports an Automatic Gain Control (AGC) circuit. Long term degradation of signal strength by the build up of dirt on optical surfaces will not generate an alarm because of compensation provided by the AGC circuit. This operates by comparing the received signal against a standard over a predefined time interval which is nominally 1.5 hours, if the signal strength deviates by more than 7% over this time span the Receiver gain is automatically adjusted to compensate.

Fault Detection

The Control Unit is capable of detecting failures within the System. In the event of a System failure being detected the fault relay is activated.

System failures will be caused by:

- The TEST/RESET switch in the Control Unit set to the ON position
- Total loss of power or a supply reduction below the specified minimum to the Control Unit.
- The System is unable to settle during the power on AGC stabilisation period.
- The System AGC circuits have reached the limit of compensation.
- The signal has been reduced by more than 93% for approximately 10 seconds.
- The beam path is completely blocked.
- A Transmitter failure.
- Loss of power to the Transmitter.
- A Receiver failure.
- Misalignment of the Transmitter and Receiver resulting in a signal loss of greater than 93%

Detector Positioning

It is important that the Fireray 2000 Detector is positioned correctly to minimise the detection time.

Experiments have shown that smoke from a fire does not rise directly upwards, but fans out or mushrooms due to air currents and heat layering effects. The time to signal a fire condition depends on the location of the Detector within the premises, the volume of smoke produced, construction of the roof, and ventilation arrangements.

The maximum distance either side of the beam axis is found to be typically 7.5 metres for satisfactory detection under flat ceilings.

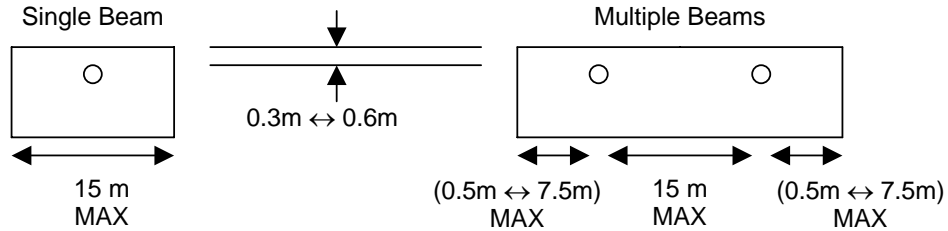

Smoke layering, where smoke does not reach the ceiling level due to layers of static hot air is over come by mounting the Detector at the recommended height below the ceiling of between 0.3 and 0.6 metres, bringing the infrared beam below the heat layer and into the smoke layer.

However in all installations the national fire standards for that particular country must be consulted. If there is any doubt on the correct mounting height, positioning may be determined by smoke tests.

Detector Positioning In Apex Of Sloping Ceiling

A ceiling is defined as sloping if the distance from the top of the apex to the intersection of the ceiling and adjacent wall is greater than 0.6 metres (See fig. 1).

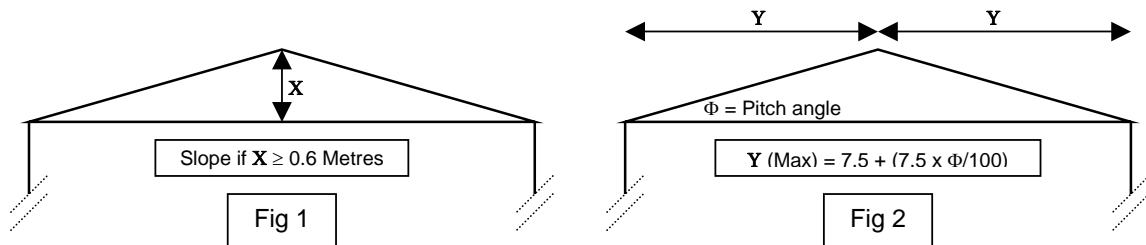

When a Detector is positioned in the apex of a ceiling (See fig. 2). The lateral beam distance covered (Y) can be increased in relation to the angle of pitch (Φ).

For Example:

If the pitch angle is 20 degrees the lateral coverage can be increased from 7.5 metres either side of the beam (Y) to:

$$Y = 7.5 + (7.5 \times 20/100) \text{ metres}$$

$$Y = 9 \text{ metres}$$

Therefore with a roof pitch of 20 degrees the lateral coverage can be increased from 7.5 metres either side of the beam to 9 metres either side of the beam, but only for the beam positioned in the apex. All other calculations remain the same.

This formula can be applied to pitch angles up to and including 25 degrees. Therefore the maximum increase in lateral coverage can be:

$$Y = 7.5 + (7.5 \times 25/100) \text{ metres}$$

$$Y = 9.375 \text{ metres}$$

Pitch angles over 25 degrees must use the maximum lateral figure of 9.375 metres either side of the beam.

Installation

Pre-installation at Ground Level

Confirm that all parts have been supplied as listed in the parts list. See page 8.

Control Unit

1. There are 20mm knockout holes on all side faces for fixing of cable glands. Four 7mm fixing holes are located on the rear surface of the box, which are to be used to locate the Control Unit to the building structure.
2. Select the required alarm threshold (See fig. 7 for switch configuration settings). The factory default setting is 35% this should be adequate for most environments, if the Detector is to be installed into an exceptionally dirty environment change the threshold to 50%.
3. Select latching or auto reset for the alarm relay. The factory default setting is auto reset, change this option if required (See fig. 7 for switch configuration settings).
4. Select the AGC compensation setting; to comply with BS5839 leave the switch open, this is the default factory setting. At the last AGC stage the Fireray will signal a fault, but in the event of any further signal loss reducing the signal to the selected sensitivity level will result in a fire alarm (See fig. 7 for switch configuration settings). If the switch is closed, at the last AGC stage the Fireray will signal a fault but the fire relay will be inhibited.
5. Mount the Control Unit at ground level to a flat surface, preferably a wall, using the fixing holes provided. Ease of access is essential for system commissioning and "follow on" service calls.
6. Terminate the field wiring (See figs. 5 & 6 for wiring instructions).

Transmitter and Receiver

1. Confirm that the Transmitter Power is set to maximum (See fig 3).
2. Locate positions for both Transmitter and Receiver using the positioning methods described earlier.
3. Ensure there is a clear line between the Transmitter and the Receiver. No more than 3 metres of the beams path should be within 500mm of any wall or partition. Make sure that no single object is within 300mm of the centre of the beam.
4. Fix the right angle brackets provided to a solid structure, which is not effected by thermal and or mechanical movement.

► **Do not fix to plaster board or cladded walls as these surfaces do and will move** ◀

4. Mount the Transmitter and Receiver heads using the 'U' brackets provided onto the right angle brackets (See fig 3 for details).
5. Wire the Receiver to the Control Unit using not less than 5 metres and no more than 100 metres of good quality 3 core screened cable, make sure all junction boxes used are metal and terminated with the cable screen. At the Control Unit terminate the screen at the entry gland (See fig 6 for details)

Do not terminate the screen inside the Control Unit.

Alignment

Receiver

1. Mechanically align the Receiver as accurately as possible (by eye) to the Transmitter.
2. Apply power to the Control Unit and check the voltage is within the operating parameters of 11.5 – 28 Volts.

Transmitter

1. Mechanically align the Transmitter as accurately as possible (by eye) to the Receiver.
2. Wire the Transmitter to a power supply (See fig 6 for details).
3. Apply power to the Transmitter and check the voltage is within the operating parameters of 11.5 – 28 Volts.

Alignment Method 'A' Using Fireray 2000 Alignment Tool

1. Connect the Fireray 2000 alignment tool (optional extra – contact sales for details) to the Control Unit.
2. Position the Alignment Tool so that the LED's are visible from the Transmitter
3. On the Control Unit PCB set the RESET/TEST switch to ON, and adjust the signal level potentiometer to 12 'o'clock
4. Adjust the Transmitter orientation whilst observing the LED's on the Alignment Tool.
5. If the green LED is steady and moving the Transmitter in any direction causes the green LED to flash, the beam is aligned. Leave the Transmitter in the steady green LED position (go to 8).
6. If moving the Transmitter in any direction causes the red LED to flash, move the Transmitter in that direction to obtain the red flashing LED (go to 7).
7. If the red LED flashes reduce the power of the Transmitter by removing the cap on the side of the Transmitter (See fig 3) and using a small screwdriver turn the potentiometer clockwise until the red LED stops flashing and the green LED stays steady (go to 5).
8. Secure the Transmitter by tightening both the screws in the bracket and recheck the Alignment Tool LED.
9. Continue to Final Settings After Alignment.

Alignment Method 'B' Using Voltmeter

1. Connect a voltmeter to the Test Meter terminal and ground on the Control Unit PCB.
2. On the Control Unit PCB set the RESET/TEST switch to ON, and adjust the signal level potentiometer to 12 'o'clock
3. Adjust the Transmitter orientation whilst observing the reading on the voltmeter.
4. If a voltage of 4.8 ± 0.1 volts is observed and moving the Transmitter in any direction causes the voltage to drop, the beam is aligned. Leave the Transmitter in the 4.8 ± 0.1 volts output position (go to 7).
5. If moving the Transmitter in any direction causes the voltage to increase, move transmitter in that direction to obtain the highest voltage (go to 6).
6. If a voltage of 4.9 to 5.1 volts is observed, reduce the power of the Transmitter by removing the cap on the side of the Transmitter (See fig 3) and using a small screwdriver turn the potentiometer clockwise until the voltmeter reading is between 4.8 ± 0.1 volts (go to 4).
7. Secure the Transmitter by tightening both the screws in the bracket and recheck the voltage.
8. Continue to Final Settings After Alignment.

Final Settings After Alignment

1. At the Control Unit adjust the signal level potentiometer slowly anticlockwise until the signal HIGH LED just extinguishes.
2. Confirm that the output at the Test Meter terminal is 4.2 ± 0.1 volts.
3. Disconnect the voltmeter and or the alignment tool wires from the Test Meter terminals.
4. Confirm that both signal HIGH and signal LOW LED'S are both OFF.
5. Move the RESET/TEST switch to the OFF position and confirm the fault LED extinguishes.
6. Wait 45 seconds and confirm the fault LED is still extinguished.

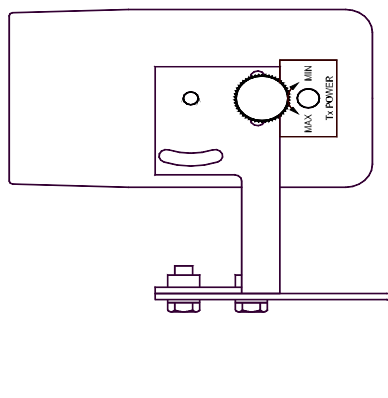

Fig 3. Transmitter Power Adjust Potentiometer

Alarm Test

1. Taking note of the threshold selected during installation (default 35%).
2. Select obscuration mark on filter to correspond with the Detector alarm threshold (see fig. 4).
3. Place the filter over the Receiver just past the correct obscuration value determined by the threshold selected. For example if a threshold of 35% has been selected position the filter just past the 35% obscuration value on the filter (see fig 4 below).
4. The Control Unit will indicate a fire within 10 seconds by activating the RED LED on the Control Unit door and operating the fire relay.

Reset After Alarm Test

1. Remove the filter from the front of the Receiver, the Control Unit will reset after approximately 4 seconds if the alarm latch option is configured as auto reset (default setting – switch open).
2. If the latching alarm option has been selected (switched closed) the Control Unit can be reset by either:
 - Switching the TEST/RESET switch to ON, then OFF.
 - Disconnect the power to the Control Unit for more than 1 second.
 - By shorting the external reset terminal on the Control Unit PCB to the negative terminal for more than 1 second.

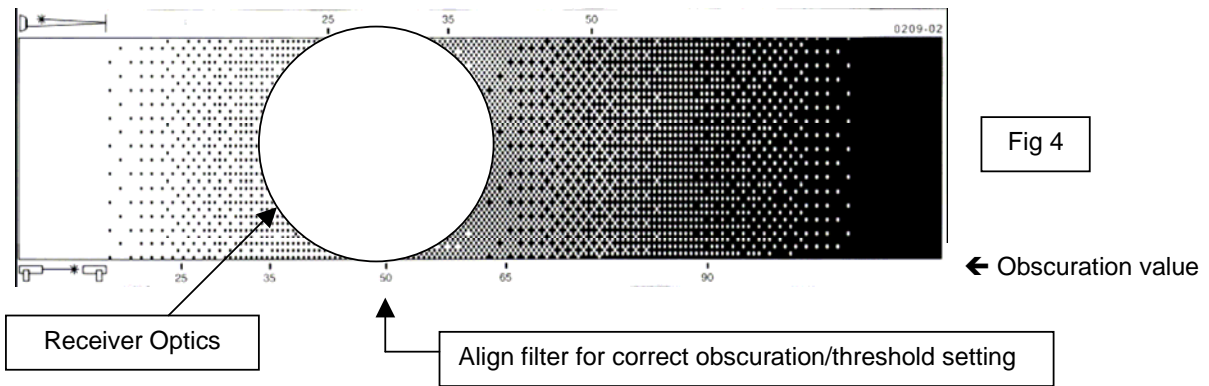

Fault Test

The fault relay and the fault LED operate if the beam is totally blocked for approximately 10 seconds. Removing the obstruction will automatically reset the beam after approximately 4 seconds.

Typical Single Zone Wiring

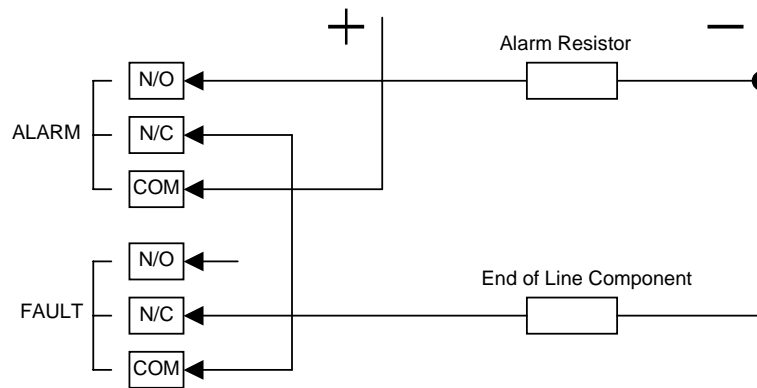

N.B. Alarm resistor and End of Line Component are not supplied. Please contact Fire Panel Manufacturer for correct values.

- + ← +VE (12-24 Vdc)
- Earth ← Earth
- ← -VE (0V Return)

Fig 5

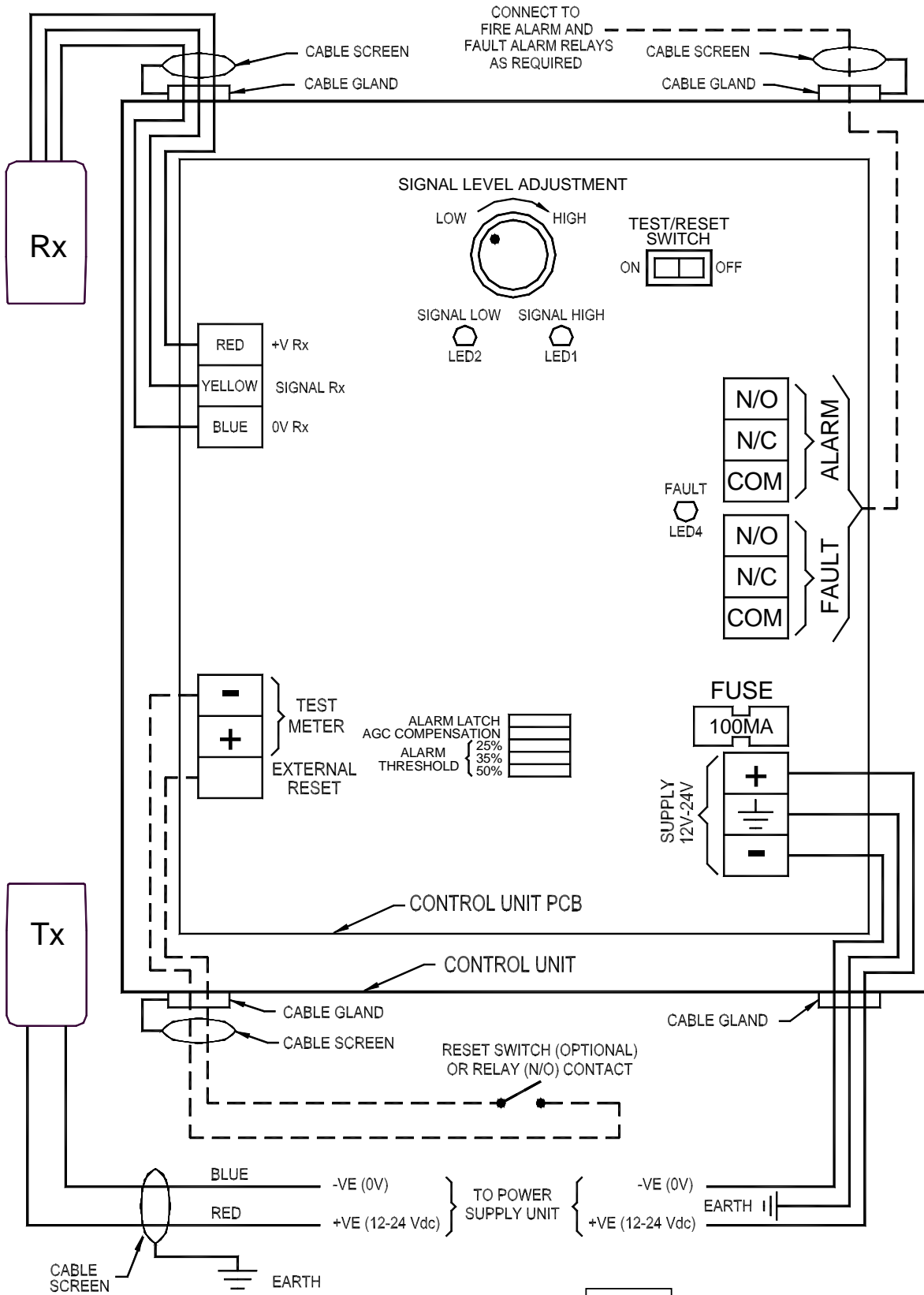

Fig 6

Technical Specifications

Data

Operating Temperature	-20°C to +55°C
Operating Voltage	11.5 to 28 Volts DC
Transmitter Current	< 1.6 – 5.6mA
Control Unit (includes Receiver) Quiescent Current	< 8.5mA
Control Unit (includes Receiver) Alarm Current	< 16.5mA
Control Unit (includes Receiver) Fault Current	< 16.5mA
Operating Range (distance between Transmitter and Receiver)	10 to 100 metres
Receiver tolerance to beam misalignment	± 4°
Transmitter tolerance to beam misalignment	± 1°
Fire alarm thresholds	1.25dB (25%), 1.87dB (35%), 3dB (50%)
Optical wavelength	880 nm (Infra red)
Control Unit max dimensions	215mm x 265mm x 88mm
Transmitter and Receiver max dimensions (inc. brackets)	83mm x 115mm x 135mm
Control Unit weight	1060 gms
Transmitter and Receiver weight (inc. brackets)	650 gms
Relay Contacts	2A 30 Volts DC resistive

Fireray 2000 Selectable Options

SWITCH	OPEN	CLOSED
ALARM LATCH	Fire relay will automatically reset ←	Fire relay will not auto reset (latch)
COMP	For BS5839 part 5 leave open. ← At the last AGC stage the Fireray will signal a fault, but in the event of any further signal loss reducing the signal to the selected threshold level, a fire alarm will be signalled	At the last AGC stage the Fireray will signal a fault, the fire relay will be inhibited
25%		25% Alarm sensitivity selected
35%		35% Alarm sensitivity selected ←
50%		50% Alarm sensitivity selected

NOTE: Select ONE Alarm sensitivity level only.

← Factory Default Settings.

Fig 7

Application Notes

For full compliance with BS5839 part 5, use the 25% and 35% thresholds. The 50% threshold is only recommended for hostile environments.

Service Notes

Control Unit contains ESD sensitive devices; appropriate care must be taken when handling internal components.

Parts List

- 1 Transmitter (clear lens).
- 1 Receiver (dark lens).
- 1 Control Unit.
- 2 Right angle brackets.
- 4 Bolts and washers.
- 1 Test Filter.

FIRE FIGHTING ENTERPRISES LIMITED
9 Hunting Gate, Wilbury Way, Hitchin
Hertfordshire SG4 0TJ England
☎Tel: +44 (0) 845 4024242 ☏Fax: +44 (0) 845 4024201 ✉Email: sales@ffeuk.com
www.ffeuk.com